

HAITIAN INTERNATIONAL HOLDINGS LIMITED

Unit 1105 Level 11
Metroplaza Tower 2
223 Hing Fong RD Kwai Fong N.T
haitian@mail.haitian.com
www.haitian.com

NINGBO HAITIAN HUAYUAN MACHINERY CO., LTD.

Export Processing Zone, Ningbo 315800 China
+86-574-86177242
+86-574-86221864
haitian@mail.haitian.com
www.haitian.com

HAITIAN HUAYUAN MIDDLE EAST MK. DIS TIC. LTD. STI.

Alkop San.Sit.B/6 Blok No:8-9
Hadimköy/Büyüçkekmece/İstanbul
Tel:0212 858 10 58
Fax:0212 858 10 57
Internet URL:http// www.haitian.com



SPECIFICATIONS

GLOBAL



HAITIAN MARS III SERIES

Energy-saving servo injection molding machines

600 - 12,000 kN

HT 20200929-TV



SPESİFİKASYON

TECHNICAL DATE
TEKNİK B LG
MACHINE TYPE
MAKİNE T P

	MA600 III /130			MA900 III /280			MA1200 III /400			MA1600 III /570			
	A	B		A	B	C	A	B	C	A	B	C	
ENJEKSİYON ÜNİTESİ													
Vida Çapı	mm	24	28	32	36	40	36	40	45	40	45	50	
Vide Boy/Çap oranı	L/D	23.3	20	22.5	20	18	23.3	21	18.7	22.5	20	18	
Teorik enjeksiyon hacmi	cm ³	50	68	121	153	188	173	214	270	253	320	395	
Enjeksiyon Kapasitesi (PS)	g	45	62	110	139	172	157	194	246	230	291	359	
Enjeksiyon Oranı	g/s	62	84	99	125	154	125	154	195	149	188	232	
Enjeksiyon Basıncı	MPa	250	184	234	185	150	229	186	147	225	178	144	
Plastikleşme Hızı (GPPS) ①	g/s	6.0	8.6	12.5	16.5	20.0	18.4	22.6	29.8	21.9	29.2	36.7	
Plastikleşme Hızı (HDPE) ②	g/s	-	-	-	-	-	-	-	-	-	-	-	
Vida Devir Hızı	rpm	0-310			0-285			0-285			0-265		
MENGENE ÜNİTESİ													
Kilitleme Gücü	kN	600			900			1200			1600		
Mengene Stroğu	mm	270			310			360			430		
Kolonlar Arası Mesafe	mm	310x310			360x360			410x410			470x470		
Max.Kalıp Kalınlığı	mm	330			390			450			520		
Min.Kalıp Kalınlığı	mm	120			150			150			180		
İtici Stroğu	mm	70			100			120			140		
İtici Gücü	kN	22			33			33			33		
DİĞERLERİ													
Pompa motor Gücü	kW	13			15			18.5			22		
Isıtıcı Gücü	kW	6.3			7.7			11.75			11.75		
Makina Boyutları	m	3.87x1.06x1.89			4.22x1.16x1.95			4.84x1.19x2.05			5.36x1.37x2.10		
Makina Ağırlığı	t	2.5			3.35			4.35			5.65		
Mal Hazne Kapasitesi	kg	25			25			25			25		
Yağ Tankı Kapasitesi	l	120			150			170			210		

Plaka Ebatları

Hareketli Plaka

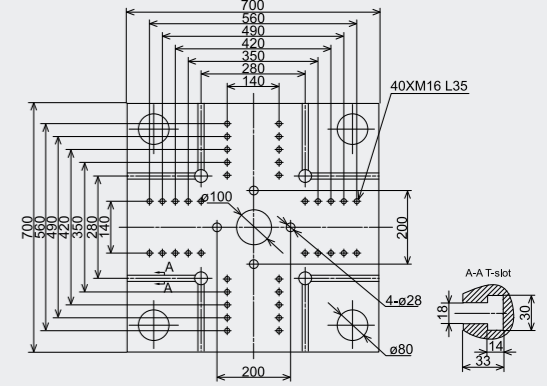
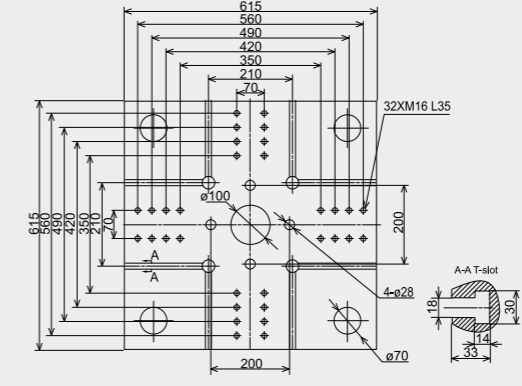
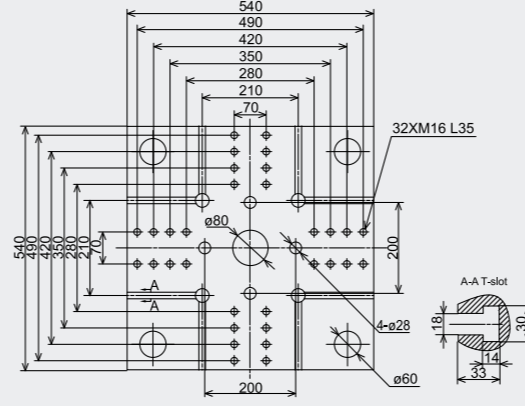
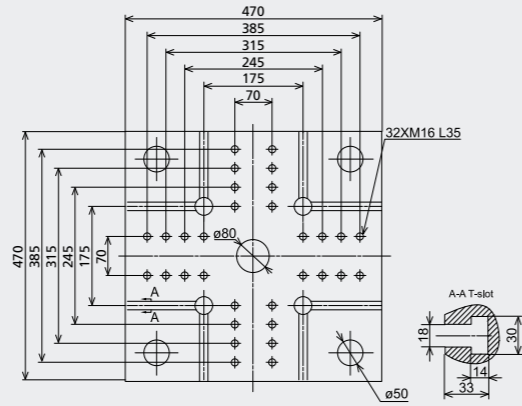

Plaka Ebatları

Robot bağlantı delikleri sabit plakada

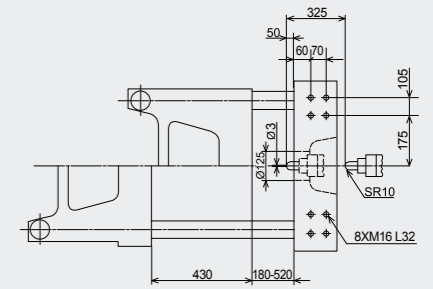
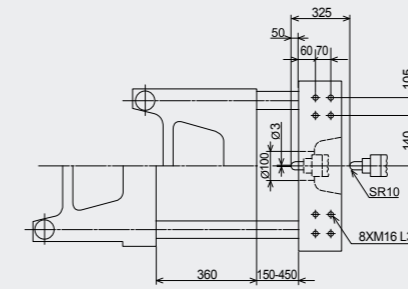
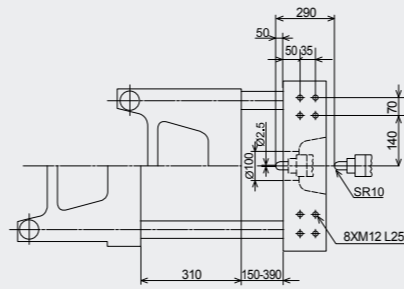
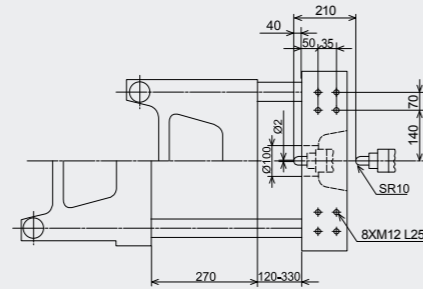

Makina Boyutları

- ① plastikleştirme kapasitesi (GPPS) : çin standardı GB / 22530-2010, 3 bölge vidaların GPPS plastikleştirme kapasitesi uygulaması ile
- ② plastikleştirme kapasitesi (HDPE) : Euromap 19, bariyer vidalarının HDPE plastikleştirme kapasitesi uygulaması ile

We reserve the right to make changes as a result of further technical advantages.

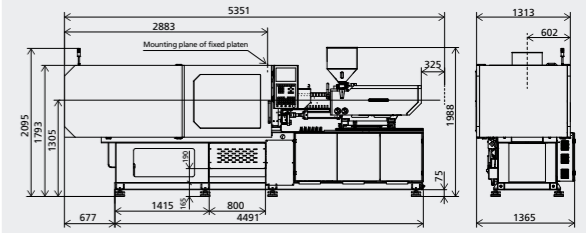
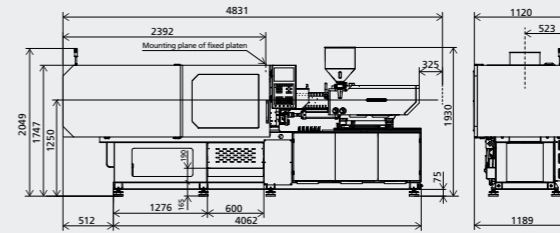
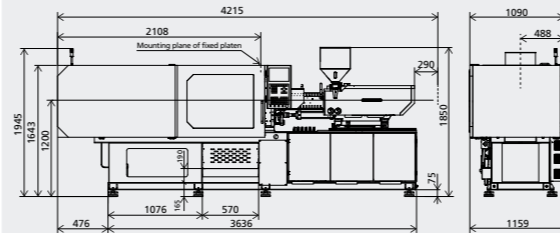
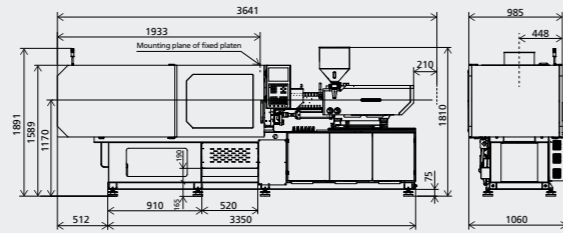

SPESİFİKASYON

TECHNICAL DATE
TEKNİK B LG
MACHINE TYPE
MAKİNE T P

	MA2000 III /750			MA 2500 III /1000			MA2800 III /1350			MA3200 III /1700		
	A	B	C	A	B	C	A	B	C	A	B	C
ENJEKSİYON ÜNİTESİ												
Vida Çapı	mm	45	50	55	60	65	70	75	80	85	90	95
Vide Boy/Çap oranı	L/D	22.2	20	18.2	22	20	18.3	21.8	20	18.5	21.7	20
Teorik enjeksiyon hacmi	cm ³	334	412	499	471	570	679	618	735	863	792	1078
Enjeksiyon Kapasitesi (PS)	g	304	375	454	429	519	618	562	669	785	720	981
Enjeksiyon Oranı	g/s	188	232	281	232	281	335	281	334	392	296	403
Enjeksiyon Basıncı	MPa	223	180	149	224	185	155	223	188	160	213	182
Plastikleşme Hızı (GPPS) ①	g/s	24.5	30.8	37.6	38.9	47.7	56.5	45.0	53.4	59.4	51.1	56.7
Plastikleşme Hızı (HDPE) ②	g/s		-			-			-		72	81
Vida Devir Hızı	rpm		0-205		0-240			0-250			0-225	
MENGENE ÜNİTESİ												
Kilitleme Gücü	kN		2000		2500			2800			3200	
Mengene Stroğu	mm		490		540			590			640	
Kolonlar Arası Meseafe	mm		530x530		580x580			630x630			680x680	
Max.Kalıp Kalınlığı	mm		550		580			630			680	
Min.Kalıp Kalınlığı	mm		200		220			230			250	
İtici Stroğu	mm		140		150			150			160	
İtici Gücü	kN		62		62			62			62	
DİĞERLERİ												
Pompa motor Gücü	kW		30		37			45			45	
Isıtıcı Gücü	kW		16.95		17.8			23.4			27	
Makina Boyutları	m		5.85x1.44x2.20		6.17x1.52x2.27			6.62x1.77x2.41			7.09x1.86x2.38	
Makina Ağırlığı	t		7.1		8.4			11.7			13.5	
Mal Hazne Kapasitesi	kg		50		50			50			50	
Yağ Tankı Kapasitesi	l		250		340			440			500	

Plaka Ebatları

Hareketli Plaka

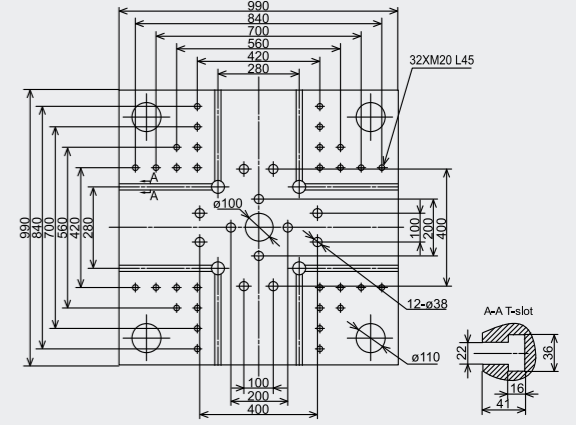
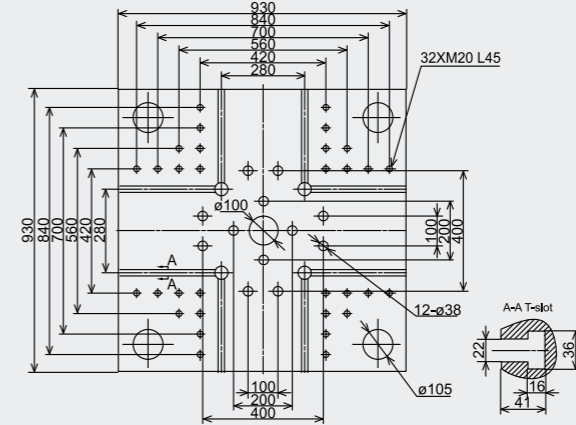
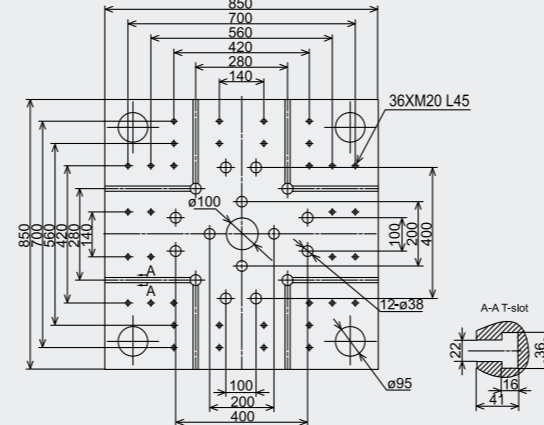
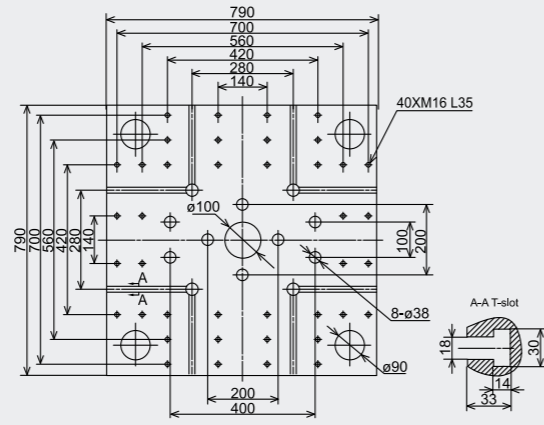

Plaka Ebatları

Robot bağlantı delikleri sabit plakada

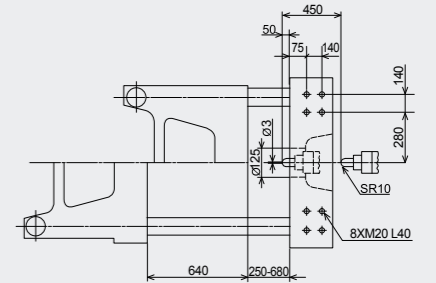
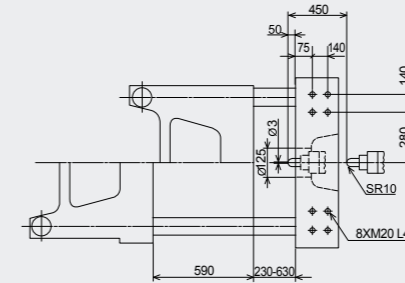
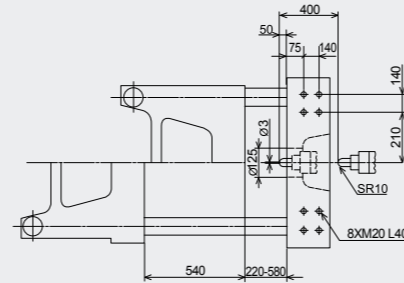
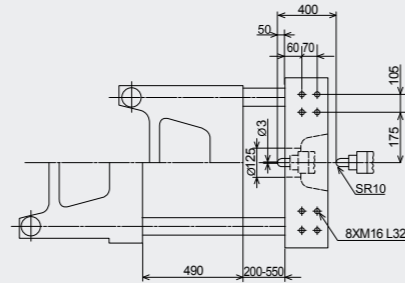

Makina Boyutları

- ① plastikleştirme kapasitesi (GPPS) : çin standardı GB / 22530-2010, 3 bölge vidaların GPPS plastikleştirme kapasitesi uygulaması ile
- ② plastikleştirme kapasitesi (HDPE) : Euromap 19, bariyer vidalarının HDPE plastikleştirme kapasitesi uygulaması ile

We reserve the right to make changes as a result of further technical advantages.

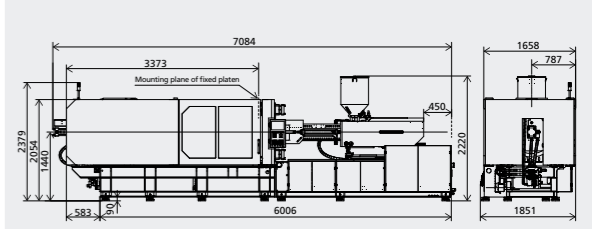
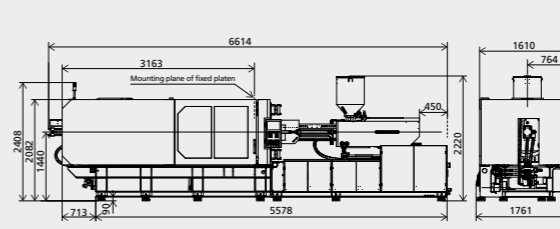
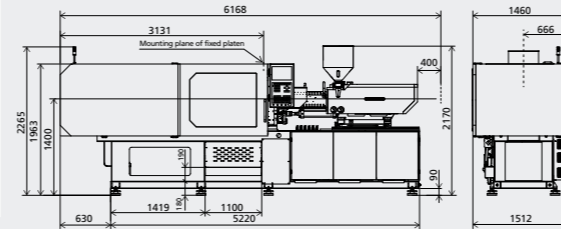
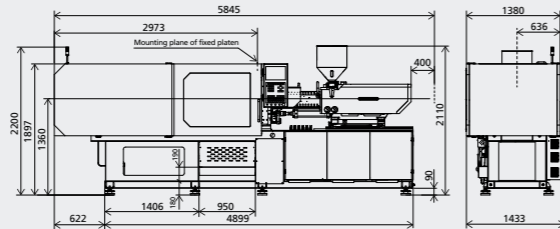

SPESİFİKASYON

TECHNICAL DATE
TEKNİK B LG
MACHINE TYPE
MAKİNE T P

	MA3800 III /2250				MA4700 III /3200				MA5300 III /4500				
	A	B	C	D	A	B	C	D	A	B	C	D	
ENJEKSİYON ÜNİTESİ													
Vida Çapı	mm	65	70	75	80	70	80	85	90	80	85	90	100
Vide Boy/Çap oranı	L/D	21.5	20	18.7	17.5	22.9	20	19.1	17.8	22	20.7	19.6	17.6
Teorik enjeksiyon hacmi	cm ³	1068	1239	1423	1619	1424	1860	2100	2354	2212	2497	2799	3456
Enjeksiyon Kapasitesi (PS)	g	972	1128	1295	1473	1296	1692	1911	2142	2013	2272	2547	3145
Enjeksiyon Oranı	g/s	369	427	491	558	427	558	630	706	558	630	706	872
Enjeksiyon Basıncı	MPa	212	183	159	140	224	172	152	136	197	175	156	126
Plastikleşme Hızı (GPPS) ①	g/s	58.6	67.3	76.1	84.4	67.9	89.5	98.3	111.1	78.1	86.3	98.6	119.8
Plastikleşme Hızı (HDPE) ②	g/s	83.8	100	112	126	97.2	131	148	170	113.5	126.2	142.1	175
Vida Devir Hızı	rpm	0-220				0-210				0-175			
MENGENE ÜNİTESİ													
Kilitleme Gücü	kN	3800				4700				5300			
Mengene Stroğu	mm	700				780				850			
Kolonlar Arası Mesafe	mm	730x730				820x800				840x830			
Max.Kalıp Kalınlığı	mm	730				780				850			
Min.Kalıp Kalınlığı	mm	280				320				350			
İtici Stroğu	mm	180				200				220			
İtici Gücü	kN	110				110				158			
DİĞERLERİ													
Pompa motor Gücü	kW	55				65				22+55			
Isıtıcı Gücü	kW	33				38.95				48			
Makina Boyutları	m	7.51x1.88x2.33				8.24x2.03x2.55				9.0x2.07x2.72			
Makina Ağırlığı	t	15.1				19.6				24			
Mal Hazne Kapasitesi	kg	50				50				100			
Yağ Tankı Kapasitesi	l	540				640				800			

Plaka Ebatları

Hareketli Plaka

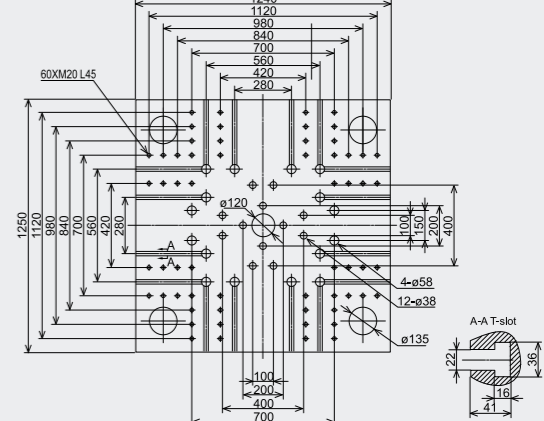
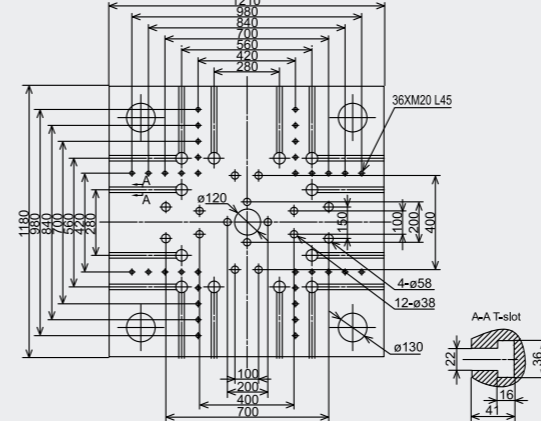
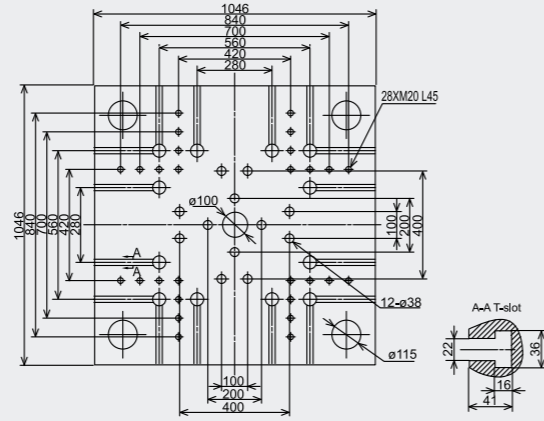

Plaka Ebatları

Robot bağlantı delikleri sabit plakada

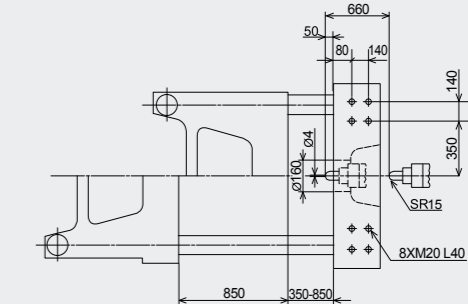
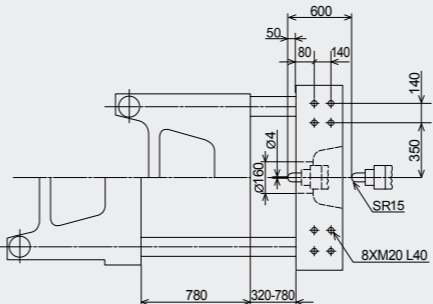
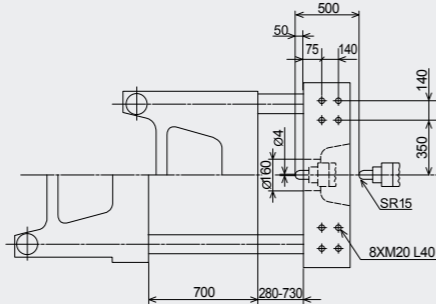

Makina Boyutları

- ① plastikleştirme kapasitesi (GPPS) : çin standardı GB / 22530-2010, 3 bölge vidaların GPPS plastikleştirme kapasitesi uygulaması ile
② plastikleştirme kapasitesi (HDPE) : Euromap 19, bariyer vidalarının HDPE plastikleştirme kapasitesi uygulaması ile

We reserve the right to make changes as a result of further technical advantages.

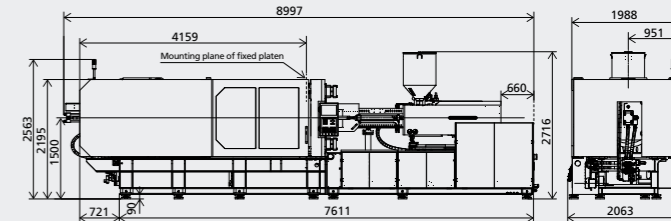
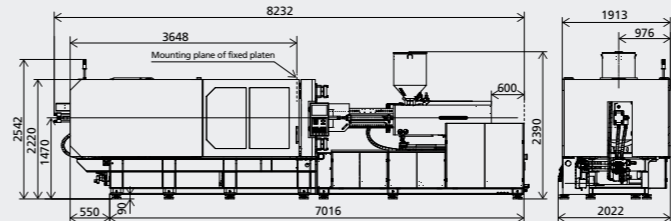
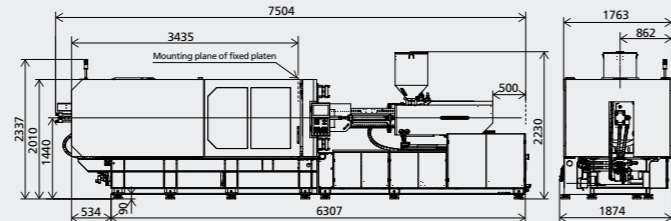

SPESİFİKASYON

TECHNICAL DATE
TEKNİK B LG
MACHINE TYPE
MAKİNE T P

	MA6000 III /4500				MA7000 III /5000				MA8000 III /6800				
	A	B	C	D	A	B	C	D	A	B	C	D	
ENJEKSİYON ÜNİTESİ													
Vida Çapı	mm	80	85	90	100	80	90	100	110	90	100	110	120
Vide Boy/Çap oranı	L/D	22	20.7	19.6	17.6	24.8	22	19.8	18	24.4	22	20	18.3
Teorik enjeksiyon hacmi	cm ³	2212	2497	2799	3456	2262	2863	3534	4276	2990	3691	4467	5316
Enjeksiyon Kapasitesi (PS)	g	2013	2272	2547	3145	2058	2605	3216	3892	2721	3359	4065	4837
Enjeksiyon Oranı	g/s	558	630	706	872	517	654	808	977	590	729	882	1050
Enjeksiyon Basıncı	MPa	197	175	156	126	226	179	145	120	219	178	147	123
Plastikleşme Hızı (GPPS) ①	g/s	78.1	86.3	98.6	119.8	73.3	92.0	113	133	89.5	110	130	152
Plastikleşme Hızı (HDPE) ②	g/s	113.5	126.2	142.1	175	108	137	169	199	132	162	193	224
Vida Devir Hızı	rpm	0-175				0-150				0-135			
MENGENE ÜNİTESİ													
Kilitleme Gücü	kN	6000				7000				8000			
Mengene Stroğu	mm	900				970				1040			
Kolonlar Arası Meseafe	mm	880x880				960x940				1000x1000			
Max.Kalıp Kalınlığı	mm	880				940				1000			
Min.Kalıp Kalınlığı	mm	380				400				420			
İtici Stroğu	mm	240				260				280			
İtici Gücü	kN	158				186				186			
DİĞERLERİ													
Pompa motor Gücü	kW	22+55				30+55				37+55			
Isıtıcı Gücü	kW	48				54.3				70.6			
Makina Boyutları	m	9.24x2.09x2.72				10.41x2.24x2.74				11.02x2.30x2.81			
Makina Ağırlığı	t	27				32				38			
Mal Hazne Kapasitesi	kg	100				100				100			
Yağ Tankı Kapasitesi	l	800				880				1000			

Plaka Ebatları

Hareketli Plaka

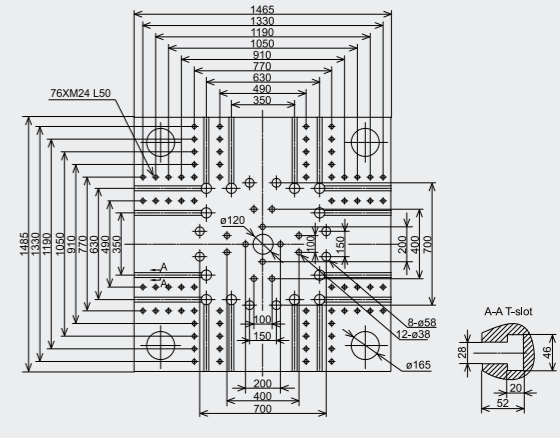
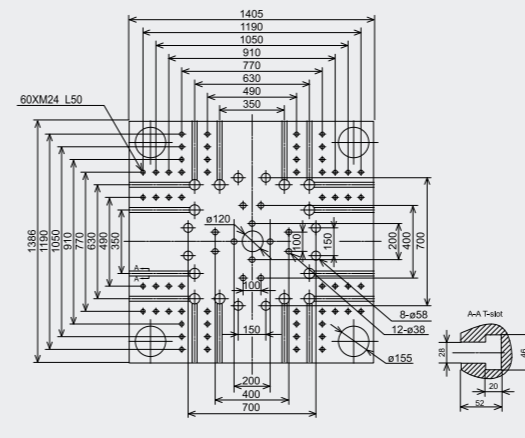
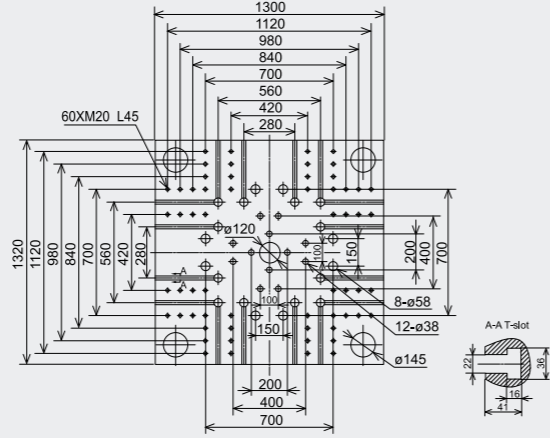

Plaka Ebatları

Robot bağlantı delikleri sabit plakada

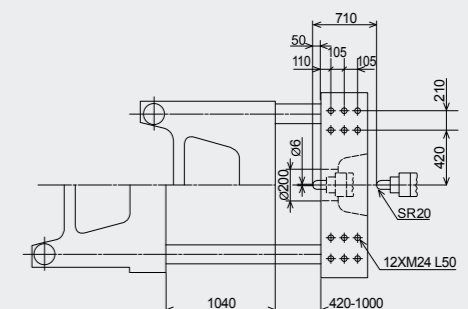
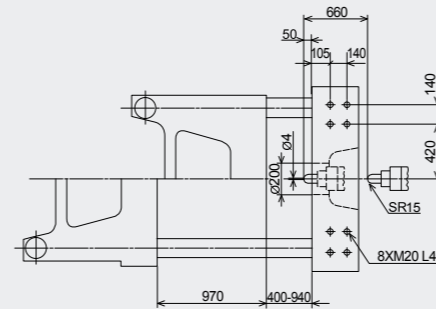
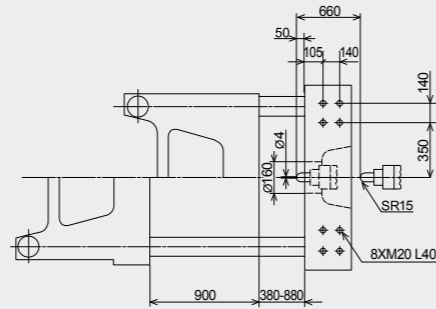

Makina Boyutları

- ① plastikleştirme kapasitesi (GPPS) : çin standardı GB / 22530-2010, 3 bölge vidaların GPPS plastikleştirme kapasitesi uygulaması ile
- ② plastikleştirme kapasitesi (HDPE) : Euromap 19, bariyer vidalarının HDPE plastikleştirme kapasitesi uygulaması ile

We reserve the right to make changes as a result of further technical advantages.

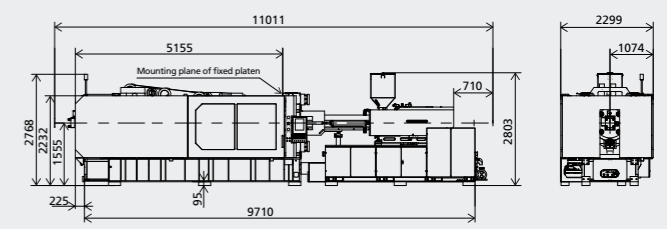
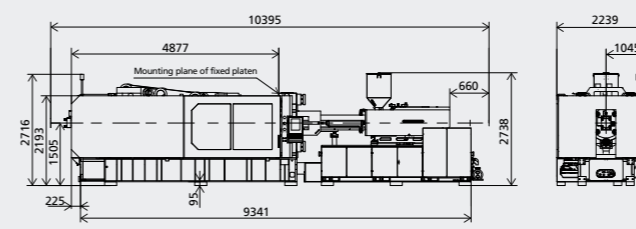
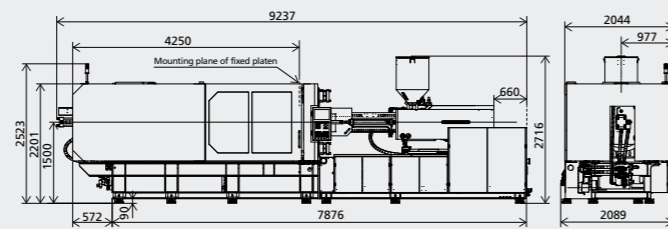

SPESİFİKASYON

TECHNICAL DATE
TEKNİK BİLGİ
MACHINE TYPE
MAKİNE TİPİ

	MA9000 III /6800				MA10000 III /8400				MA12000 III /8400				
	A	B	C	D	A	B	C	D	A	B	C	D	
ENJEKSİYON ÜNİTESİ													
Vida Çapı	mm	90	100	110	120	100	110	120	130	100	110	120	130
Vide Boy/Çap oranı	L/D	24.4	22	20	18.3	24.2	22	20.2	18.6	24.2	22	20.2	18.6
Teorik enjeksiyon hacmi	cm ³	2990	3691	4467	5316	4006	4847	5768	6769	4006	4847	5768	6769
Enjeksiyon Kapasitesi (PS)	g	2721	3359	4065	4837	3645	4410	5249	6160	3645	4410	5249	6160
Enjeksiyon Oranı	g/s	590	729	882	1050	715	865	1030	1208	715	865	1030	1208
Enjeksiyon Basıncı	MPa	219	178	147	123	213	176	148	126	213	176	148	126
Plastikleşme Hızı (GPPS) ①	g/s	89.5	110	130	152	100	120	139	160	100	120	139	160
Plastikleşme Hızı (HDPE) ②	g/s	132	162	193	224	146	175	199	229	146	175	199	229
Vida Devir Hızı	rpm	0-135				0-115				0-115			
MENGENE ÜNİTESİ													
Kilitleme Gücü	kN	9000				10000				12000			
Mengene Stroğu	mm	1120				1220				1310			
Kolonlar Arası Mesafe	mm	1080x1080				1160x1160				1250x1250			
Max.Kalıp Kalınlığı	mm	1080				1160				1250			
Min.Kalıp Kalınlığı	mm	450				500				550			
İtici Stroğu	mm	300				320				320			
İtici Gücü	kN	186				215				215			
DİĞERLERİ													
Pompa motor Gücü	kW	37+55				37+65				37+65			
Isıtıcı Gücü	kW	70.6				82.8				82.8			
Makina Boyutları	m	11.29x2.42x2.81				12.05x2.49x2.85				12.42x2.61x2.94			
Makina Ağırlığı	t	45				49				59			
Mal Hazne Kapasitesi	kg	100				100				100			
Yağ Tankı Kapasitesi	l	1000				1150				1150			

Plaka Ebatları

Hareketli Plaka

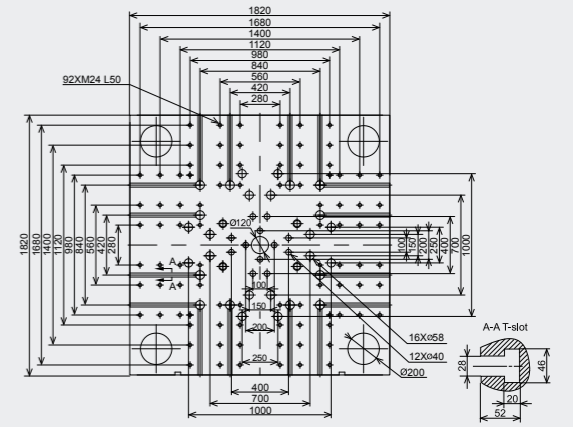
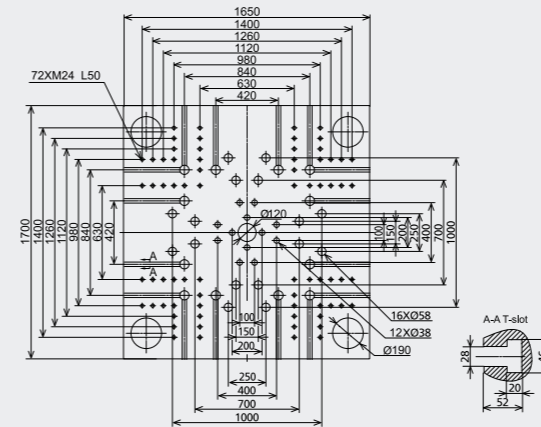
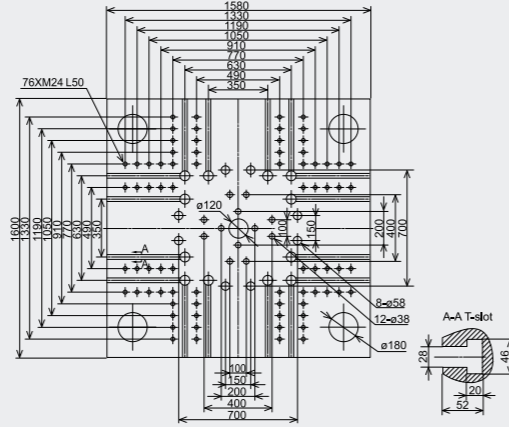

Plaka Ebatları

Robot bağlantı delikleri sabit plakada

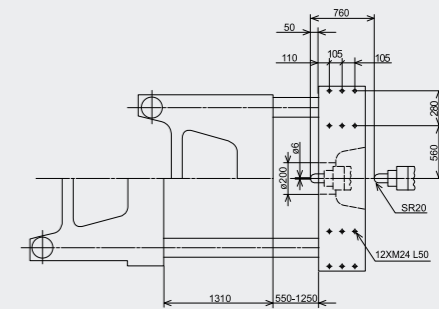
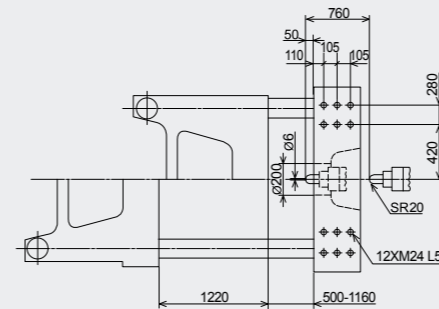
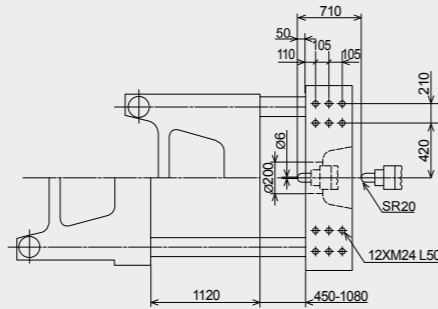

Makina Boyutları

- ① plastikleştirme kapasitesi (GPPS) : çin standardı GB / 22530-2010, 3 bölge vidaların GPPS plastikleştirme kapasitesi uygulaması ile
② plastikleştirme kapasitesi (HDPE) : Euromap 19, bariyer vidalarının HDPE plastikleştirme kapasitesi uygulaması ile

We reserve the right to make changes as a result of further technical advantages.

