

HAITIAN INTERNATIONAL HOLDINGS LIMITED

Unit 1105 Level 11
Metroplaza Tower 2
223 Hing Fong RD Kwai Fong N.T
haitian@mail.haitian.com
www.haitian.com

NINGBO HAITIAN HUAYUAN MACHINERY CO., LTD,

Export Processing Zone, Ningbo 315800 China
Tel +86-574-86177242
Fax +86-574-86221864
haitian@mail.haitian.com
www.haitian.com



SPECIFICATIONS



HAITIAN JUPITER III SERIES

The 3rd Generation of Servo Hydraulic Two-platen Solution

4.500 - 10.800 kN

JU 2018126-IV



WE CREATE ADVANTAGE...  A MEMBER OF HAITIAN INTERNATIONAL

Combination Possibilities

4.500 - 10.800 kN

	CLAMPING UNIT		INJECTION UNIT													
MACHINE TYPE	1730	2230	3430	4630	5330	6730	8930	11300	17300	22300	32300	40300	50300	62300	93300	106300
JU4500III	Standard range	Standard range	Combination possibilities	Combination possibilities												
JU5500III		Combination possibilities	Standard range	Combination possibilities												
JU6500III		Combination possibilities	Combination possibilities	Standard range	Combination possibilities											
JU7500III			Combination possibilities	Combination possibilities	Standard range	Combination possibilities										
JU9000III					Combination possibilities	Standard range	Combination possibilities									
JU10800III					Combination possibilities	Combination possibilities	Standard range	Combination possibilities								
JU12000III																
JU13000III																
JU14000III																
JU16000III																
JU18500III																
JU24000III																
JU28000III																
JU33000III																
JU40000III																

SPECIFICATION JU4500III

SPECIFICATIONS
INJECTION UNIT

	1730	JU4500III								3430	4630						
		2230															
CLAMPING UNIT																	
Clamping force	kN	4500										kN					
Space between tie bars	mm	810×800										mm					
Max. mold height	mm	850										mm					
Min. mold height	mm	350										mm					
Ejector stroke	mm	250										mm					
Ejector force	kN	110										kN					
Max. daylight	mm	1400										mm					
Min. mold dimension ①	mm	1050/550										mm					
Max. mold weight ②	t	6.5										t					
INJECTION UNIT																	
		A	B	C	A	B	C	D	A	B	C	D	A	B	C	D	
Screw diameter	mm	60	65	70	65	70	75	80	70	80	85	90	80	85	90	100	mm
Screw L /D ratio	L/D	21.7	20	18.6	21.5	20	18.7	17.5	22.9	20	18.9	17.8	22	20.7	19.6	17.6	L/D
Shot size (theoretical)	cm ³	792	929	1078	1068	1239	1423	1619	1424	1860	2100	2354	2212	2497	2799	3456	cm ³
Injection weight (PS)	g	720	846	981	972	1128	1295	1473	1296	1692	1911	2142	2013	2272	2547	3145	g
Injection rate	g/s	366	430	498	372	431	495	563	385	503	567	636	525	593	665	821	g/s
Injection pressure	Mpa	185	158	136	182	157	137	120	208	159	141	126	181	160	143	116	Mpa
Injection pressure(max)	Mpa	221	188	162	212	183	160	140	239	183	162	145	209	185	165	134	Mpa
Plasticizing capacity (GPPS) ③	g/s	56.8	63.0	71.5	60.0	68.8	77.8	86.4	71.2	93.8	103	116	78.1	86.3	98.2	120	g/s
Plasticizing capacity (HDPE) ④	g/s	80	90	105	85.7	102	114	129	102	137	155	179	113	126	142	175	g/s
Screw speed	rpm	250			225				220				175				rpm
OTHERS																	
Max. pump pressure	Mpa	25			25				25				25				Mpa
Pump motor power	kW	45			45				55				65				kW
Heating power	kW	27			33				39				48				kW
Machine dimensions (l x w x h)	m	6.87×2.17×2.33			6.87×2.17×2.33				7×2.17×2.37				7.30×2.17×2.68				m
Machine weight	t	19			20				21				23				t
Hopper capacity	kg	50			50				50				100				kg
Oil tank capacity	l	450			450				520				600				l

NOTE:

① with min. mold height / with max. mold height

② moving platen: 2/3 of max. mold weight

③ Plasticizing capacity (GPPS): note: GB standard, with application of GPPS plasticizing capacity of 3-zone screws

④ Plasticizing capacity (HDPE): note: Euromap 19, with application of HDPE plasticizing capacity of barrier screws

The above plasticizing capacity is for reference only.

We reserve the right to make changes as a result of further technical advantages.

DIMENSIONS JU4500III

Clamping Unit

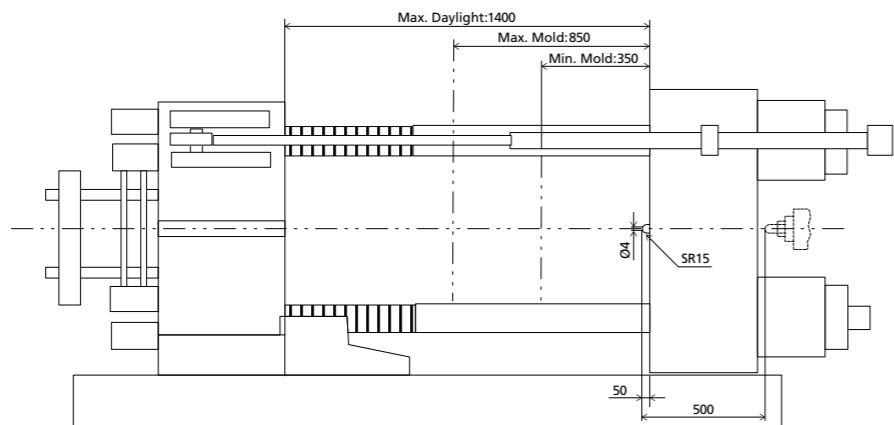

Platen dimensions

Moving platen

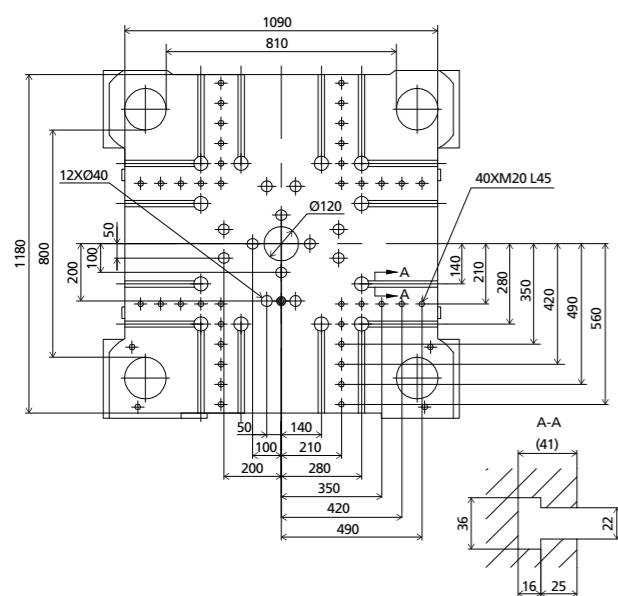

Platen dimensions

Fixed platen

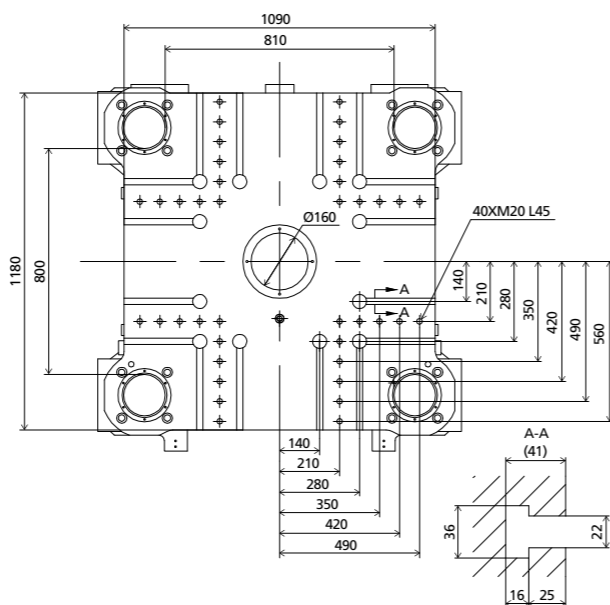

Robot

Mechanical interface

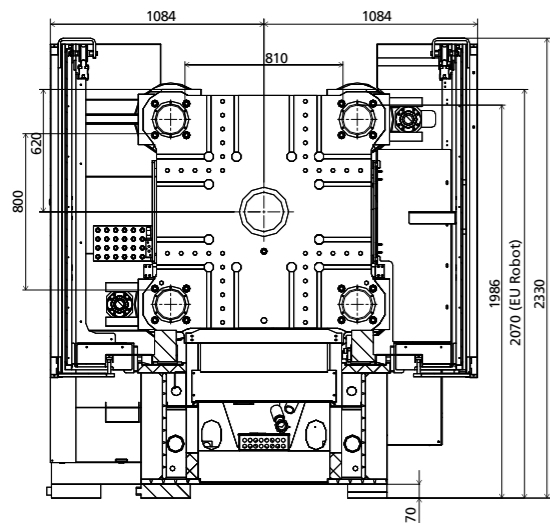

Robot

Top view fixed platen

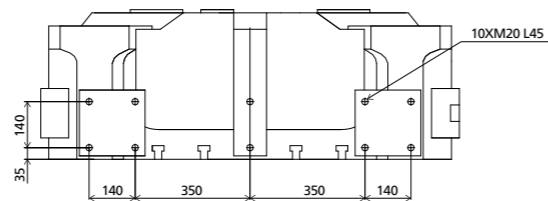

Front view

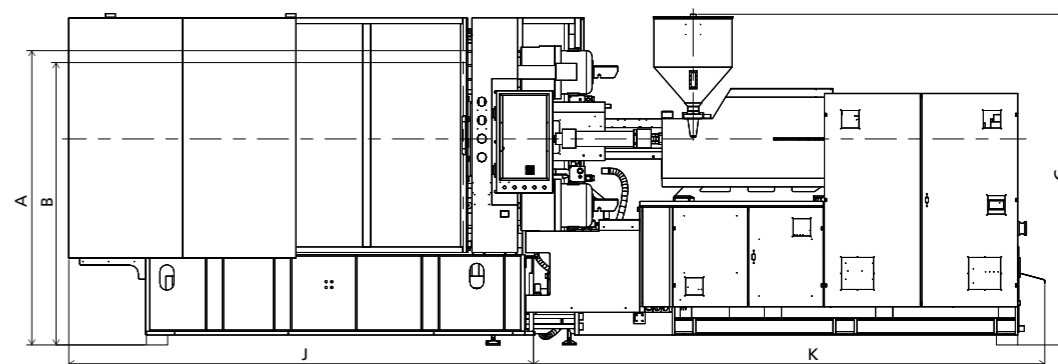

Top view

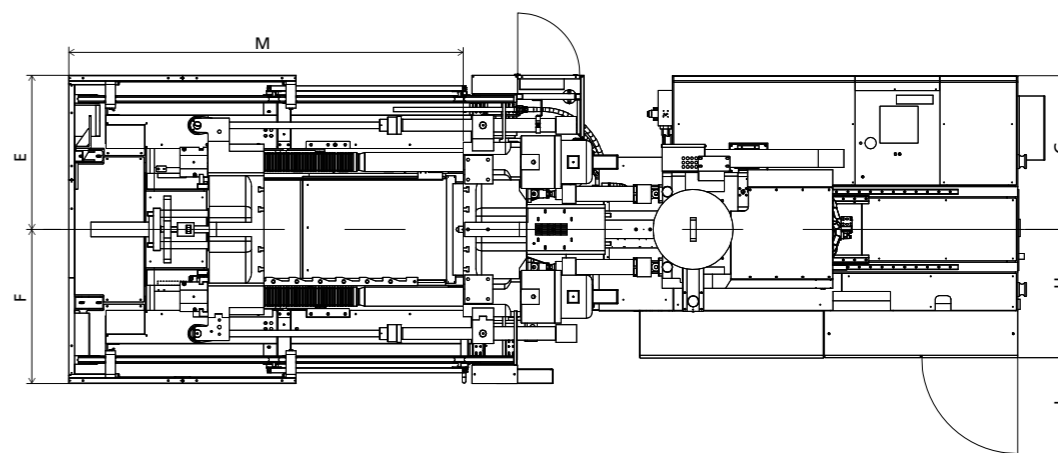

Side view

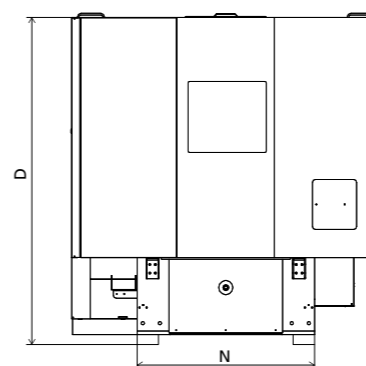

■ Standard

	A	B	C	D	E	F	G	H	I	J	K	M	N
1700	2070	1986	2317	2300	1084	1084	1082	903	675	3269	3597	2774	1248
2230	2070	1986	2327	2300	1084	1084	1082	903	675	3269	3597	2774	1248
3430	2070	1986	2366	2300	1084	1084	1082	903	675	3269	3720	2774	1248
4630	2070	1986	2671	2300	1084	1084	1177	943	675	3269	4019	2774	1248

INJECTION UNIT
DIMENSIONS (mm)

We reserve the right to make changes as a result of further technical advantages.

SPECIFICATION JU5500III

SPECIFICATIONS
INJECTION UNIT

		2230				JU5500III 3430				4630					
CLAMPING UNIT														CLAMPING UNIT	
Clamping force	kN													kN	Clamping force
Space between tie bars	mm													mm	Space between tie bars
Max. mold height	mm													mm	Max. mold height
Min. mold height	mm													mm	Min. mold height
Ejector stroke	mm													mm	Ejector stroke
Ejector force	kN													kN	Ejector force
Max. daylight	mm													mm	Max. daylight
Min. mold dimension ①	mm													mm	Min. mold dimension ①
Max. mold weight ②	t													t	Max. mold weight ②
INJECTION UNIT		A	B	C	D	A	B	C	D	A	B	C	D	INJECTION UNIT	
Screw diameter	mm	65	70	75	80	70	80	85	90	80	85	90	100	mm	Screw diameter
Screw L /D ratio	L/D	21.5	20	18.7	17.5	22.9	20	18.9	17.8	22	20.7	19.6	17.6	L/D	Screw L /D ratio
Shot size (theoretical)	cm ³	1068	1239	1423	1619	1424	1860	2100	2354	2212	2497	2799	3456	cm ³	Shot size (theoretical)
Injection weight (PS)	g	972	1128	1295	1473	1296	1692	1911	2142	2013	2272	2547	3145	g	Injection weight (PS)
Injection rate	g/s	372	431	495	563	385	503	567	636	525	593	665	821	g/s	Injection rate
Injection pressure	Mpa	182	157	137	120	208	159	141	126	181	160	143	116	Mpa	Injection pressure
Injection pressure(max)	Mpa	212	183	160	140	239	183	162	145	209	185	165	134	Mpa	Injection pressure(max)
Plasticizing capacity (GPPS) ③	g/s	60.0	68.8	77.8	86.4	71.2	93.8	103	116	78.1	86.3	98.2	120	g/s	Plasticizing capacity (GPPS) ③
Plasticizing capacity (HDPE) ④	g/s	85.7	102	114	129	102	137	155	179	113	126	142	175	g/s	Plasticizing capacity (HDPE) ④
Screw speed	rpm	225				220				175				rpm	Screw speed
OTHERS														OTHERS	
Max. pump pressure	Mpa	25				25				25				Mpa	Max. pump pressure
Pump motor power	kW	45				55				65				kW	Pump motor power
Heating power	kW	33				39				48				kW	Heating power
Machine dimensions (l x w x h)	m	7.29x2.35x2.33				7.20x2.35x2.37				7.62x2.35x2.68				m	Machine dimensions (l x w x h)
Machine weight	t	22				23				25				t	Machine weight
Hopper capacity	kg	50				50				100				kg	Hopper capacity
Oil tank capacity	l	450				520				600				l	Oil tank capacity

NOTE:

① with min. mold height / with max. mold height

② moving platen: 2/3 of max. mold weight

③ Plasticizing capacity (GPPS): note: GB standard, with application of GPPS plasticizing capacity of 3-zone screws

④ Plasticizing capacity (HDPE): note: Euromap 19, with application of HDPE plasticizing capacity of barrier screws

The above plasticizing capacity is for reference only.

We reserve the right to make changes as a result of further technical advantages.

DIMENSIONS JU5500III

Clamping Unit

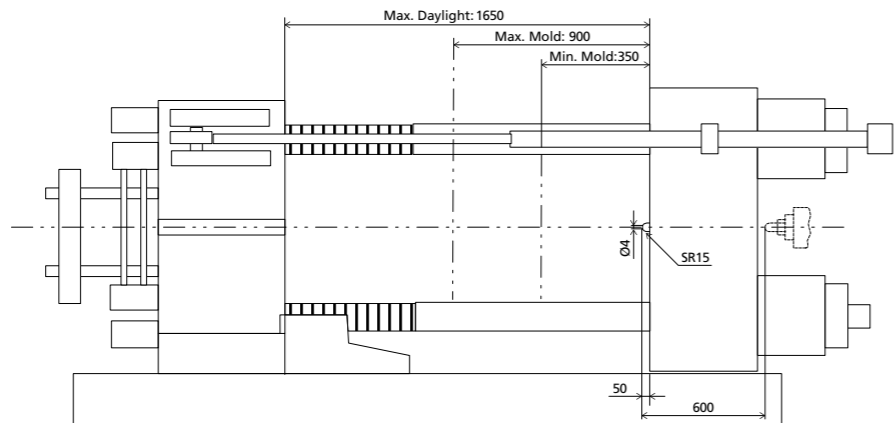

Platen dimensions

Moving platen

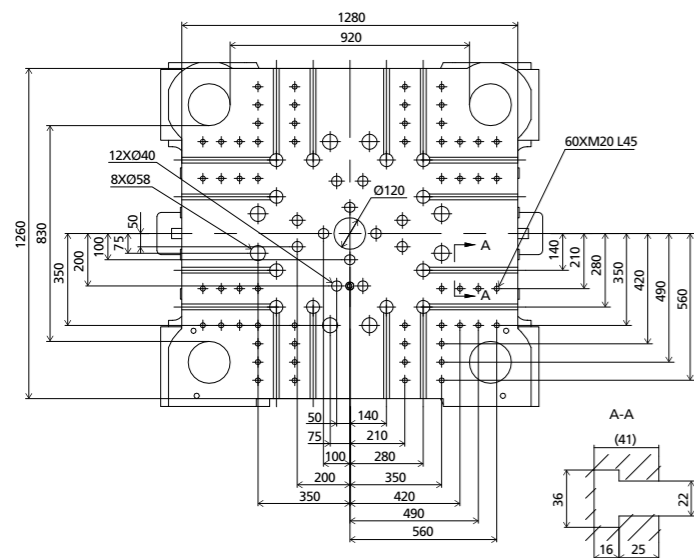

Platen dimensions

Fixed platen

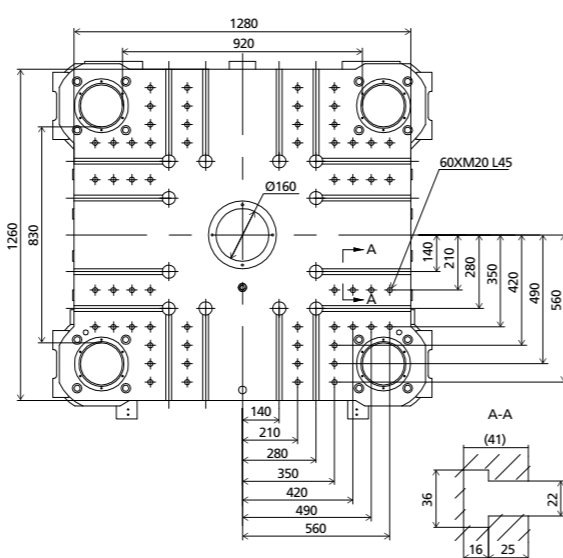

Robot

Mechanical interface

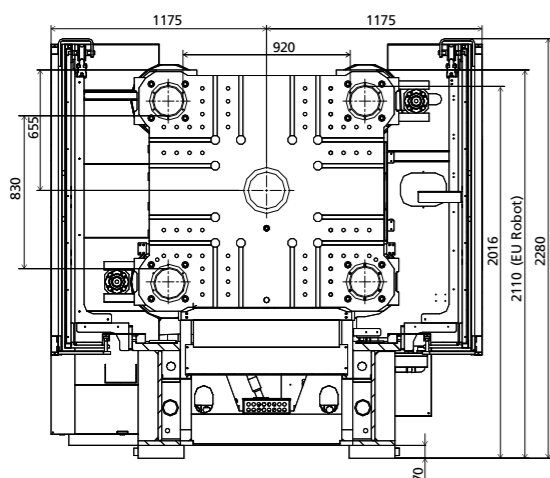

Robot

Top view fixed platen

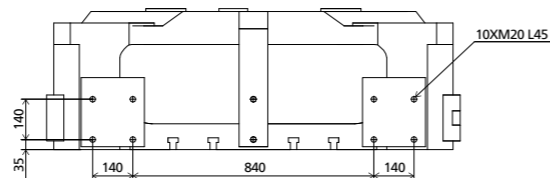

Front view

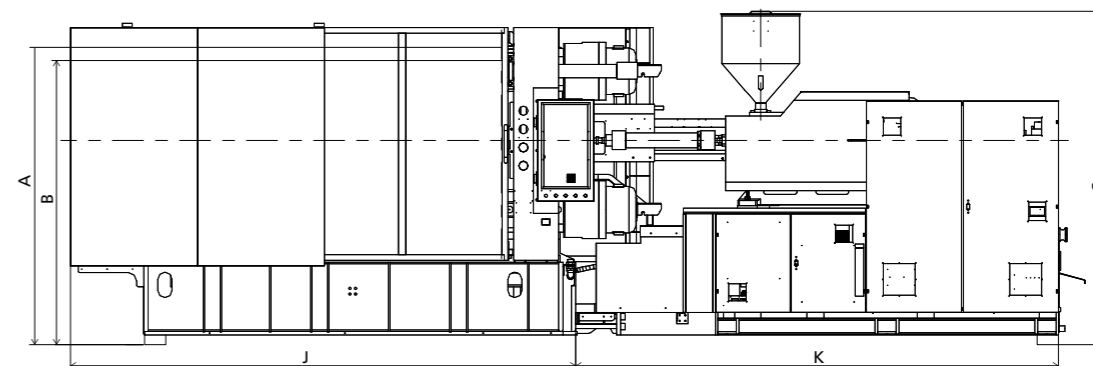

Top view

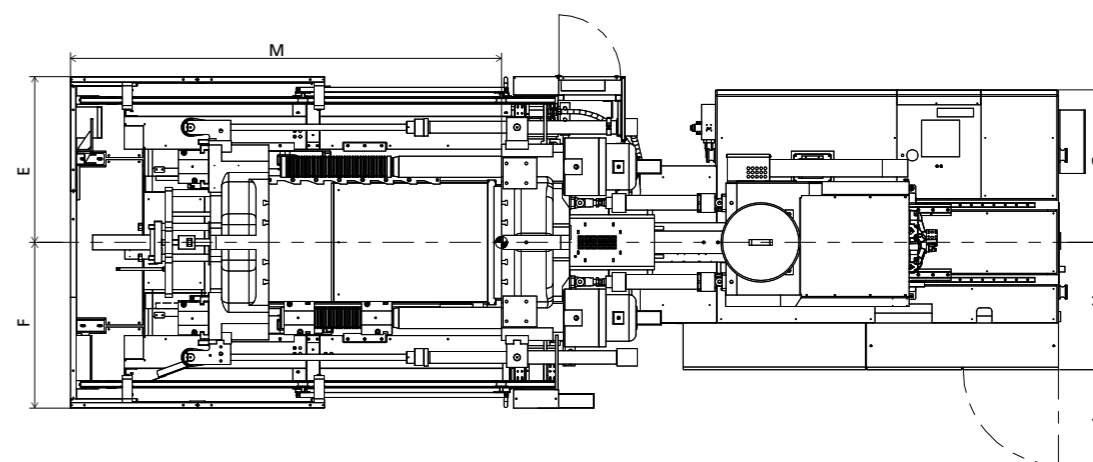

Side view

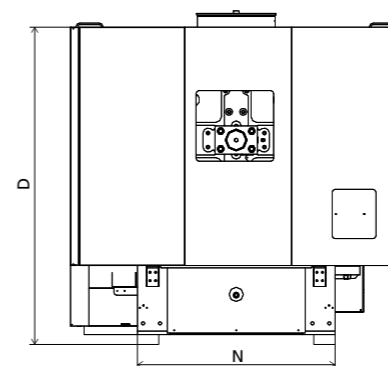

■ Standard

	A	B	C	D	E	F	G	H	I	J	K	M	N
2230	2110	2016	2327	2250	1175	1175	1082	903	675	3581	3705	3056	1400
3430	2110	2016	2366	2250	1175	1175	1082	903	675	3581	3612	3056	1400
4630	2110	2016	2671	2250	1175	1175	1177	943	675	3581	4019	3056	1400

INJECTION UNIT
DIMENSIONS (mm)

We reserve the right to make changes as a result of further technical advantages.

SPECIFICATION JU6500III

SPECIFICATIONS
INJECTION UNIT

	2230	3430	JU6500III				5330										
			4630														
CLAMPING UNIT																	
Clamping force	kN		6500				kN										
Space between tie bars	mm		1040×910				mm										
Max. mold height	mm		950				mm										
Min. mold height	mm		400				mm										
Ejector stroke	mm		250				mm										
Ejector force	kN		110				kN										
Max. daylight	mm		1750				mm										
Min. mold dimension ①	mm		1350/800				mm										
Max. mold weight ②	t		9.5				t										
INJECTION UNIT																	
		A	B	C	D	A	B	C	D	A	B	C	D				
Screw diameter	mm	65	70	75	80	70	80	85	90	80	85	90	100	80	90	100	110
Screw L /D ratio	L/D	21.5	20	18.7	17.5	22.9	20	18.9	17.8	22	20.7	19.6	17.6	24.8	22	19.8	18
Shot size (theoretical)	cm ³	1068	1239	1423	1619	1424	1860	2100	2354	2212	2497	2799	3456	2262	2863	3534	4276
Injection weight (PS)	g	972	1128	1295	1473	1296	1692	1911	2142	2013	2272	2547	3145	2058	2605	3216	3892
Injection rate	g/s	439	510	585	666	385	503	567	636	525	593	665	821	548	693	856	1036
Injection pressure	Mpa	182	157	137	120	208	159	141	126	181	160	143	116	204	161	131	108
Injection pressure (max)	Mpa	212	183	160	140	239	183	162	145	209	185	165	134	236	187	151	125
Plasticizing capacity (GPPS) ③	g/s	60.0	68.8	77.8	86.4	71.2	93.8	103	116	78.1	86.3	98.2	120	73.3	92.0	113	133
Plasticizing capacity (HDPE) ④	g/s	85.7	102	114	129	102	137	155	179	113	126	142	175	108	137	169	199
Screw speed	rpm	225				220				175				150			
OTHERS																	
Max. pump pressure	Mpa	25				25				25				25			
Pump motor power	kW	55				55				65				45+30			
Heating power	kW	33				39				48				54			
Machine dimensions (l x w x h)	m	7.48×2.58×2.33				7.50×2.58×2.37				7.68×2.58×2.67				8.36×2.58×2.69			
Machine weight	t	25				26				28				30			
Hopper capacity	kg	50				50				100				100			
Oil tank capacity	l	450				520				600				730			

NOTE:

① with min. mold height / with max. mold height

② moving platen: 2/3 of max. mold weight

③ Plasticizing capacity (GPPS): note: GB standard, with application of GPPS plasticizing capacity of 3-zone screws

④ Plasticizing capacity (HDPE): note: Euromap 19, with application of HDPE plasticizing capacity of barrier screws

The above plasticizing capacity is for reference only.

We reserve the right to make changes as a result of further technical advantages.

DIMENSIONS JU6500III

Clamping Unit

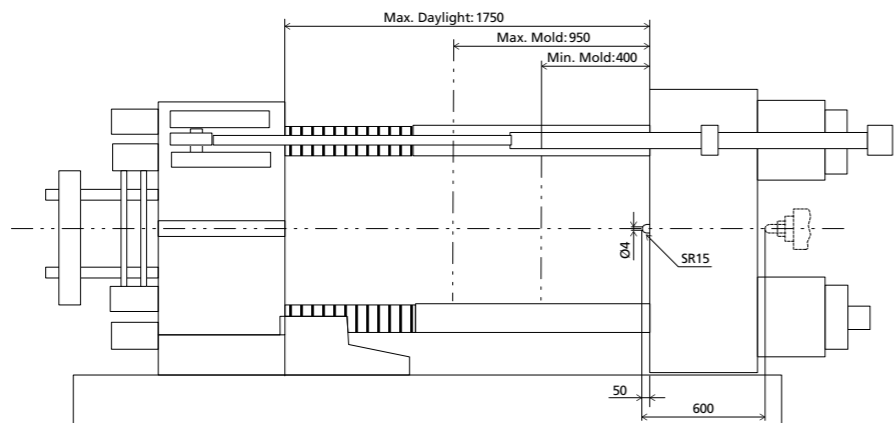

Platen dimensions

Moving platen

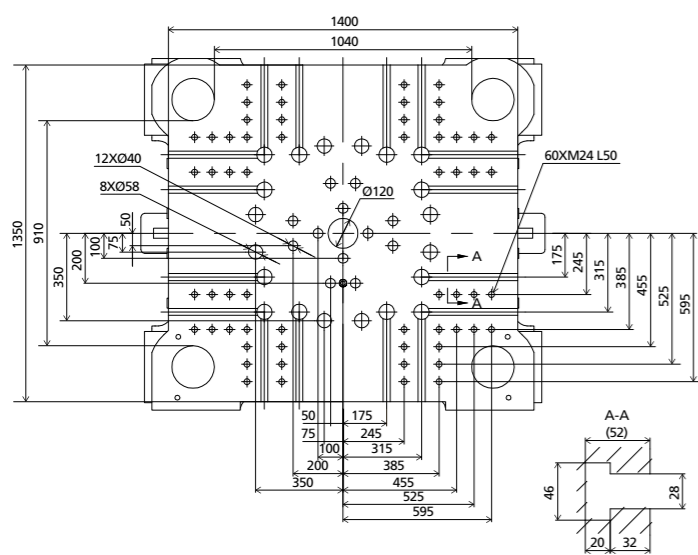

Platen dimensions

Fixed platen

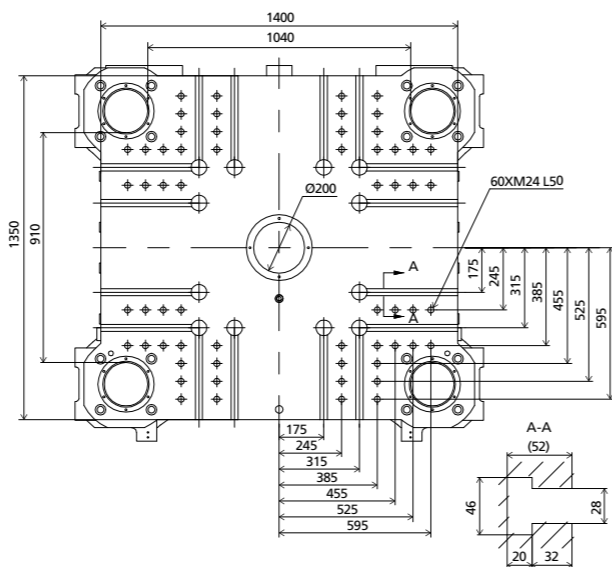

Robot

Mechanical interface

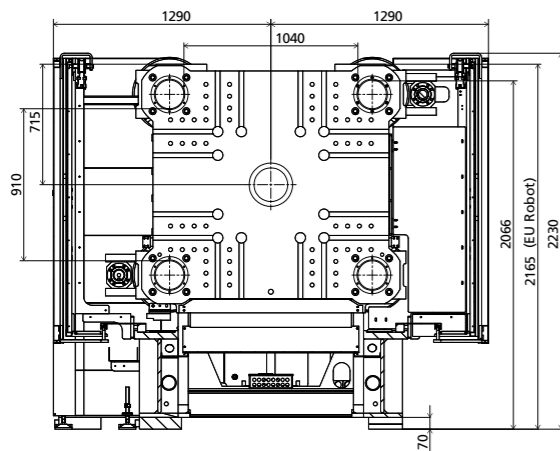

Robot

Top view fixed platen

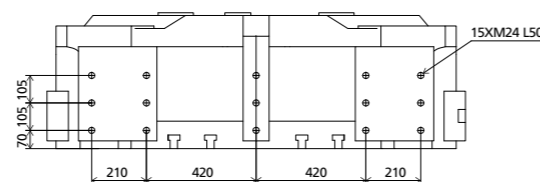

Front view

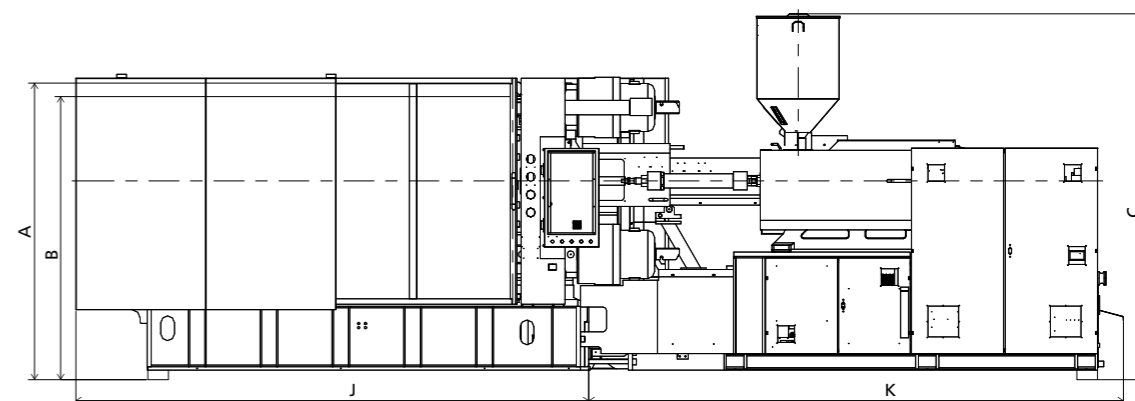

Top view

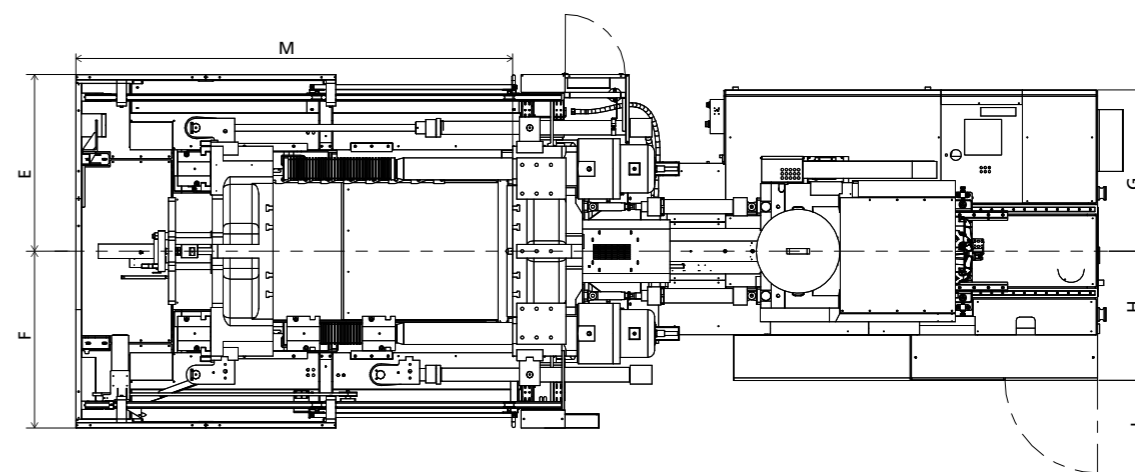

Side view

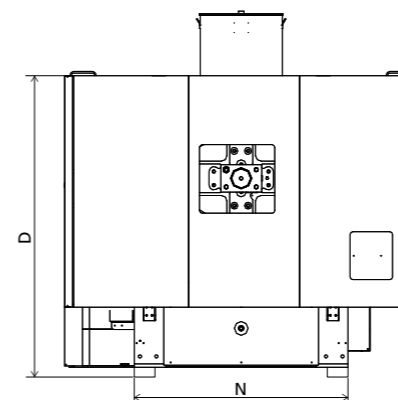

■ Standard

	A	B	C	D	E	F	G	H	I	J	K	M	N
2230	2165	2066	2327	2200	1290	1290	1082	903	675	3746	3707	3191	1560
3430	2165	2066	2366	2200	1290	1290	1082	903	675	3746	3722	3191	1560
4630	2165	2066	2671	2200	1290	1290	1177	943	675	3746	3909	3191	1560
5330	2165	2066	2686	2200	1290	1290	1207	1028	675	3746	4586	3191	1560

INJECTION UNIT
DIMENSIONS (mm)

We reserve the right to make changes as a result of further technical advantages.

SPECIFICATION JU7500III

SPECIFICATIONS
INJECTION UNIT

	3430	4630	JU7500III				5330	6730												
CLAMPING UNIT																				
Clamping force	kN					7500		kN	Clamping force											
Space between tie bars	mm					1110×960		mm	Space between tie bars											
Max. mold height	mm					950		mm	Max. mold height											
Min. mold height	mm					450		mm	Min. mold height											
Ejector stroke	mm					300		mm	Ejector stroke											
Ejector force	kN					195		kN	Ejector force											
Max. daylight	mm					1850		mm	Max. daylight											
Min. mold dimension ①	mm					1400/900		mm	Min. mold dimension ①											
Max. mold weight ②	t					11		t	Max. mold weight ②											
INJECTION UNIT																				
		A	B	C	D	A	B	C	D	A	B	C	D							
Screw diameter	mm	70	80	85	90	80	85	90	100	80	90	100	110	90	100	110	120	mm	Screw diameter	
Screw L /D ratio	L/D	22.9	20	18.9	17.8	22	20.7	19.6	17.6	24.8	22	19.8	18	24.4	22	20	18.3	L/D	Screw L /D ratio	
Shot size (theoretical)	cm ³	1424	1860	2100	2354	2212	2497	2799	3456	2262	2863	3534	4276	2990	3691	4467	5316	cm ³	Shot size (theoretical)	
Injection weight (PS)	g	1296	1692	1911	2142	2013	2272	2547	3145	2058	2605	3216	3892	2721	3359	4065	4837	g	Injection weight (PS)	
Injection rate	g/s	457	597	674	755	525	593	665	821	548	693	856	1036	642	793	960	1142	g/s	Injection rate	
Injection pressure	Mpa	208	159	141	126	181	160	143	116	204	161	131	108	193	157	129	109	Mpa	Injection pressure	
Injection pressure(max)	Mpa	239	183	162	145	209	185	165	134	236	187	151	125	222	180	149	125	Mpa	Injection pressure(max)	
Plasticizing capacity (GPPS) ③	g/s	71.2	93.8	103	116	78.1	86.3	98.2	120	73.3	92.0	113	133	89.5	110	130	152	g/s	Plasticizing capacity (GPPS) ③	
Plasticizing capacity (HDPE) ④	g/s	102	137	155	179	113	126	142	175	108	137	169	199	132	162	193	224	g/s	Plasticizing capacity (HDPE) ④	
Screw speed	rpm		220				175				150				135			rpm	Screw speed	
OTHERS																				
Max. pump pressure	Mpa		25				25				25				25			Mpa	Max. pump pressure	
Pump motor power	kW		65				65				45+30				55+30			kW	Pump motor power	
Heating power	kW		39				48				54				71			kW	Heating power	
Machine dimensions (l x w x h)	m		7.77×2.86×2.37				8.08×2.86×2.68				8.54×2.86×2.69				8.75×2.86×2.70				m	Machine dimensions (l x w x h)
Machine weight	t		28				30				32				35			t	Machine weight	
Hopper capacity	kg		50				100				100				100			kg	Hopper capacity	
Oil tank capacity	l		520				600				730				780			l	Oil tank capacity	

NOTE:

① with min. mold height / with max. mold height

② moving platen: 2/3 of max. mold weight

③ Plasticizing capacity (GPPS): note: GB standard, with application of GPPS plasticizing capacity of 3-zone screws

④ Plasticizing capacity (HDPE): note: Euromap 19, with application of HDPE plasticizing capacity of barrier screws

The above plasticizing capacity is for reference only.

We reserve the right to make changes as a result of further technical advantages.

DIMENSIONS JU7500III

Clamping Unit

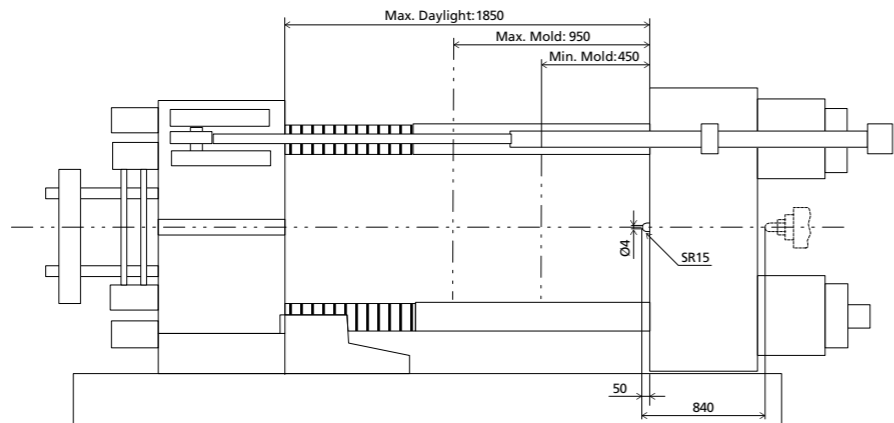

Platen dimensions

Moving platen

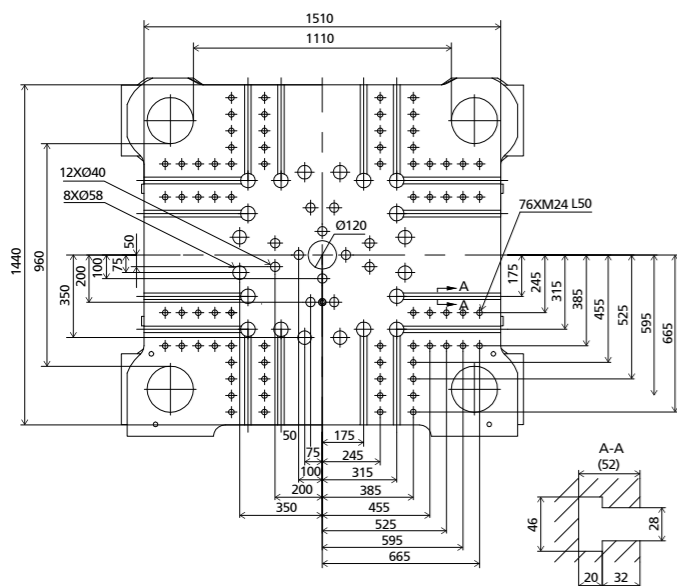

Platen dimensions

Fixed platen

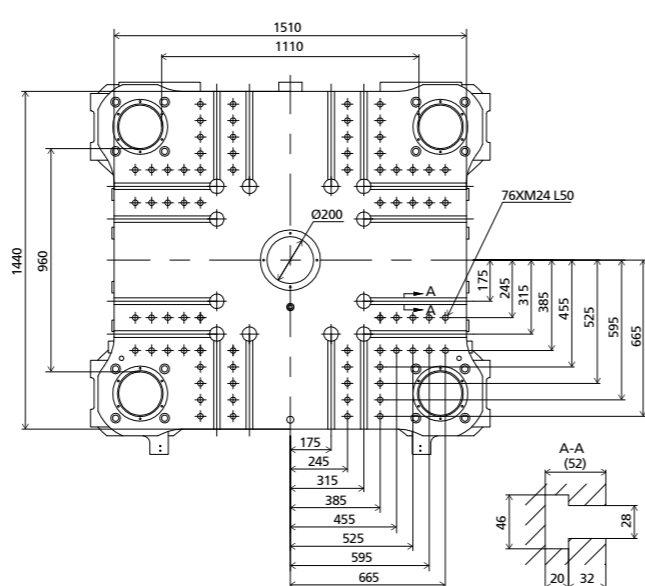

Robot

Mechanical interface

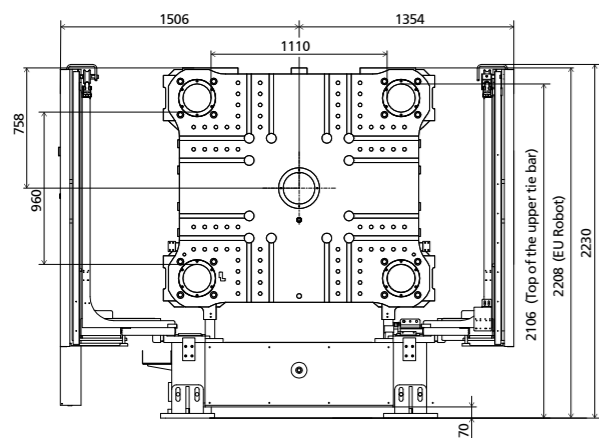

Robot

Top view fixed platen

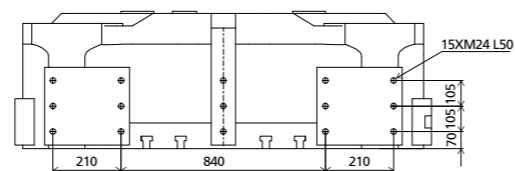

Front view

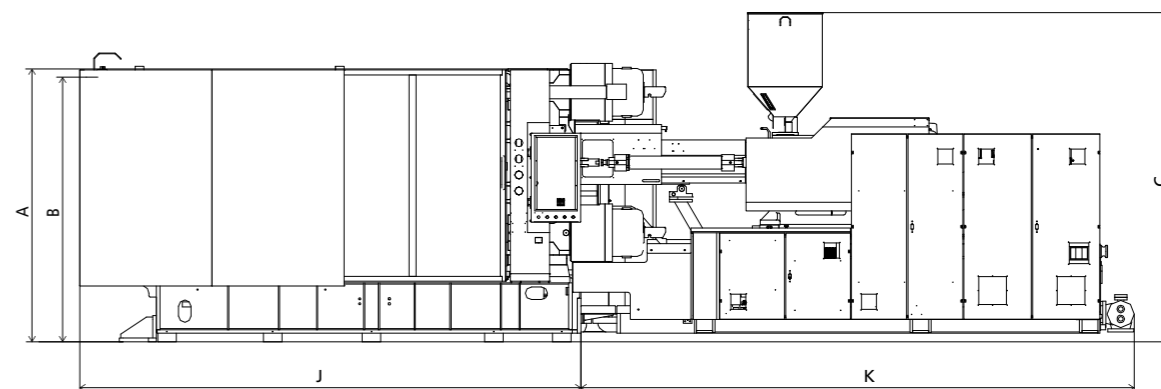

Top view

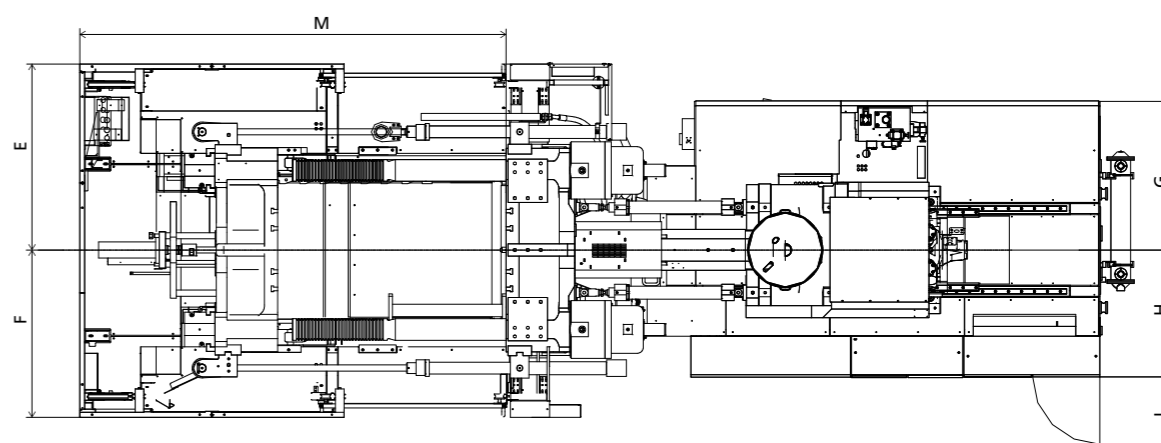

Side view

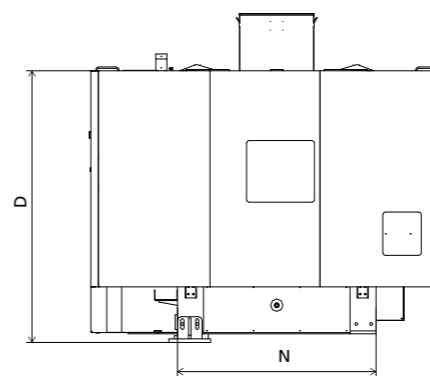

■ Standard

	A	B	C	D	E	F	G	H	I	J	K	M	N
3430	2208	2106	2366	2200	1506	1354	1078	902	675	4055	3707	3450	1607
4630	2208	2106	2671	2200	1506	1354	1258	942	675	4055	4017	3450	1607
5330	2208	2106	2685	2200	1506	1354	1203	1027	544	4055	4478	3450	1607
6730	2208	2106	2700	2200	1506	1354	1198	1042	544	4055	4689	3450	1607

INJECTION UNIT
DIMENSIONS (mm)

We reserve the right to make changes as a result of further technical advantages.

SPECIFICATION JU9000III

SPECIFICATIONS
INJECTION UNIT

		5330				JU9000III 6730				8930					
CLAMPING UNIT														CLAMPING UNIT	
Clamping force	kN													kN	Clamping force
Space between tie bars	mm													mm	Space between tie bars
Max. mold height	mm													mm	Max. mold height
Min. mold height	mm													mm	Min. mold height
Ejector stroke	mm													mm	Ejector stroke
Ejector force	kN													kN	Ejector force
Max. daylight	mm													mm	Max. daylight
Min. mold dimension ①	mm													mm	Min. mold dimension ①
Max. mold weight ②	t													t	Max. mold weight ②
INJECTION UNIT		A	B	C	D	A	B	C	D	A	B	C	D	INJECTION UNIT	
Screw diameter	mm	80	90	100	110	90	100	110	120	100	110	120	130	mm	Screw diameter
Screw L /D ratio	L/D	24.8	22	19.8	18	24.4	22	20	18.3	24.2	22	20.2	18.6	L/D	Screw L /D ratio
Shot size (theoretical)	cm ³	2262	2863	3534	4276	2990	3691	4467	5316	4006	4847	5768	6769	cm ³	Shot size (theoretical)
Injection weight (PS)	g	2058	2605	3216	3892	2721	3359	4065	4837	3645	4410	5249	6160	g	Injection weight (PS)
Injection rate	g/s	548	693	856	1036	642	793	960	1142	762	922	1097	1288	g/s	Injection rate
Injection pressure	Mpa	204	161	131	108	193	157	129	109	196	162	136	116	Mpa	Injection pressure
Injection pressure(max)	Mpa	236	187	151	125	222	180	149	125	223	184	155	132	Mpa	Injection pressure(max)
Plasticizing capacity (GPPS) ③	g/s	73.3	92.0	113	133	89.5	110	130	152	101	121	140	161	g/s	Plasticizing capacity (GPPS) ③
Plasticizing capacity (HDPE) ④	g/s	108	137	169	199	132	162	193	224	147	177	201	231	g/s	Plasticizing capacity (HDPE) ④
Screw speed	rpm	150				135				116				rpm	Screw speed
OTHERS														OTHERS	
Max. pump pressure	Mpa	25				25				25				Mpa	Max. pump pressure
Pump motor power	kW	45+30				55+30				75+37				kW	Pump motor power
Heating power	kW	54				71				83				kW	Heating power
Machine dimensions (l x w x h)	m	9.10x3.21x2.83				9.24x3.21x2.84				9.77x3.21x2.85				m	Machine dimensions (l x w x h)
Machine weight	t	38				41				43				t	Machine weight
Hopper capacity	kg	100				100				100				kg	Hopper capacity
Oil tank capacity	l	730				780				960				l	Oil tank capacity

NOTE:

① with min. mold height / with max. mold height

② moving platen: 2/3 of max. mold weight

③ Plasticizing capacity (GPPS): note: GB standard, with application of GPPS plasticizing capacity of 3-zone screws

④ Plasticizing capacity (HDPE): note: Euromap 19, with application of HDPE plasticizing capacity of barrier screws

The above plasticizing capacity is for reference only.

We reserve the right to make changes as a result of further technical advantages.

DIMENSIONS JU9000III

Clamping Unit

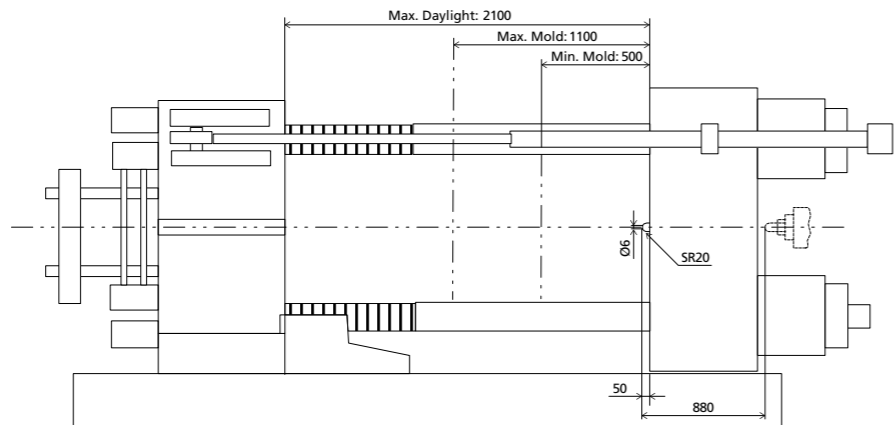

Platen dimensions

Moving platen

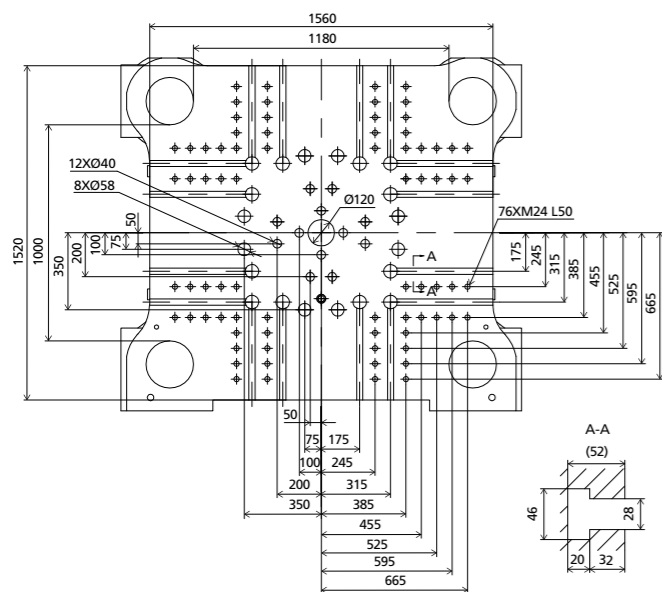

Platen dimensions

Fixed platen

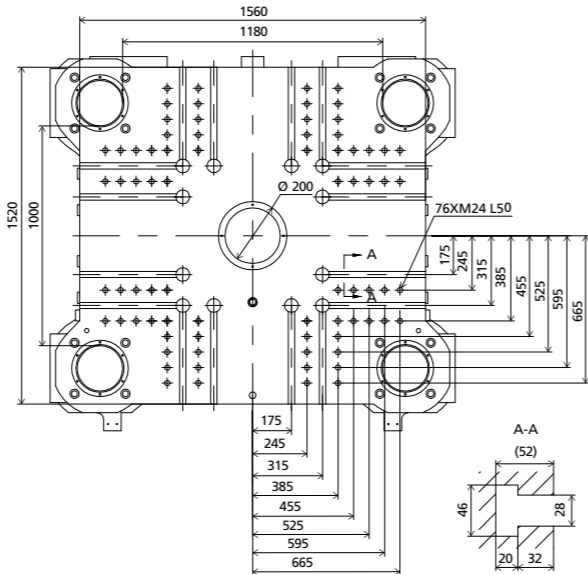

Robot

Mechanical interface

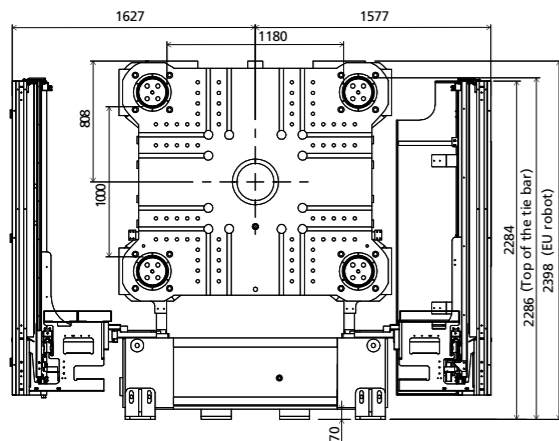

Robot

Top view fixed platen

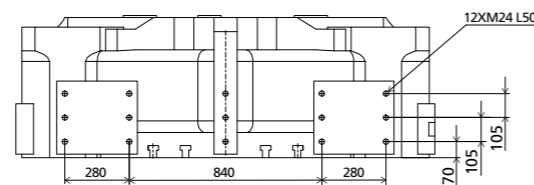

Front view

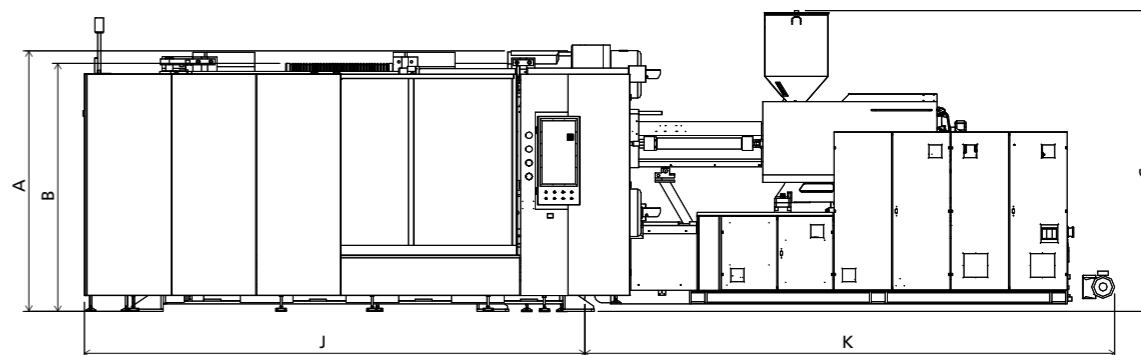

Top view

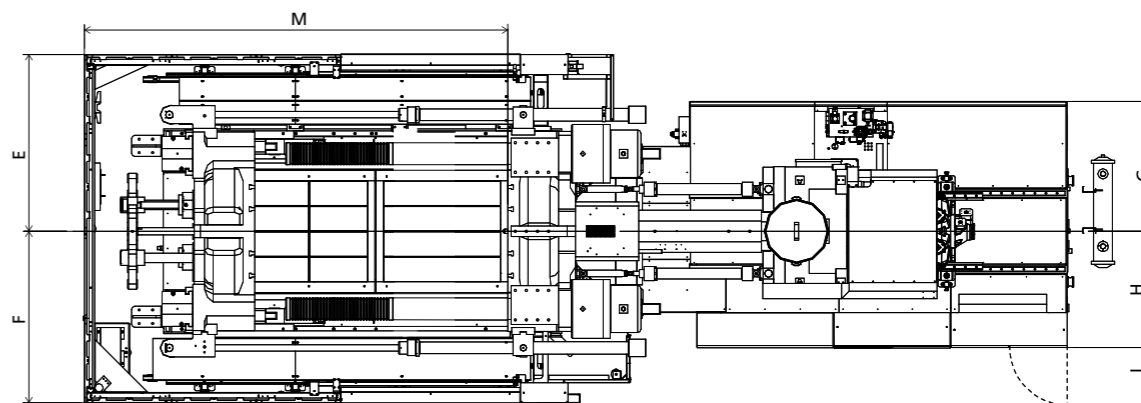

Side view

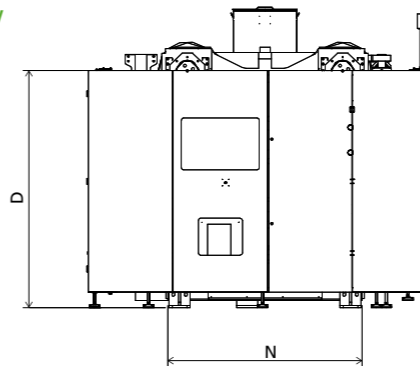

■ Standard

	A	B	C	D	E	F	G	H	I	J	K	M	N
5330	2398	2286	2825	2265	1627	1577	1203	1027	544	4512	4586	3857	1740
6730	2398	2286	2840	2265	1627	1577	1198	1042	544	4512	4581	3857	1740
8930	2398	2286	2850	2265	1627	1577	1228	1102	544	4512	5021	3857	1740

INJECTION UNIT
DIMENSIONS (mm)

We reserve the right to make changes as a result of further technical advantages.

SPECIFICATION JU10800III

SPECIFICATIONS
INJECTION UNIT

		5330				6730				JU10800III 8930				11300						
CLAMPING UNIT																		CLAMPING UNIT		
Clamping force	kN																	10800	kN	Clamping force
Space between tie bars	mm																	1260×1100	mm	Space between tie bars
Max. mold height	mm																	1200	mm	Max. mold height
Min. mold height	mm																	500	mm	Min. mold height
Ejector stroke	mm																	350	mm	Ejector stroke
Ejector force	kN																	230	kN	Ejector force
Max. daylight	mm																	2400	mm	Max. daylight
Min. mold dimension ①	mm																	1900/1200	mm	Min. mold dimension ①
Max. mold weight ②	t																	16	t	Max. mold weight ②
INJECTION UNIT		A	B	C	D	A	B	C	D	A	B	C	D	A	B	C	D	INJECTION UNIT		
Screw diameter	mm	80	90	100	110	90	100	110	120	100	110	120	130	110	120	130	140	mm	Screw diameter	
Screw L /D ratio	L/D	24.8	22	19.8	18	24.4	22	20	18.3	24.2	22	20.2	18.6	26.2	24	22.2	20.6	L/D	Screw L /D ratio	
Shot size (theoretical)	cm ³	2262	2863	3534	4276	2990	3691	4467	5316	4006	4847	5768	6769	5227	6220	7300	8467	cm ³	Shot size (theoretical)	
Injection weight (PS)	g	2058	2605	3216	3892	2721	3359	4065	4837	3645	4410	5249	6160	4756	5661	6643	7705	g	Injection weight (PS)	
Injection rate	g/s	608	770	951	1150	642	793	960	1142	762	922	1097	1288	924	1100	1291	1497	g/s	Injection rate	
Injection pressure	Mpa	204	161	131	108	193	157	129	109	196	162	136	116	190	159	136	117	Mpa	Injection pressure	
Injection pressure(max)	Mpa	236	187	151	125	222	180	149	125	223	184	155	132	218	183	156	135	Mpa	Injection pressure(max)	
Plasticizing capacity (GPPS) ③	g/s	80.6	101	125	146	89.5	110	130	152	101	121	140	161	123	142	164	187	g/s	Plasticizing capacity (GPPS) ③	
Plasticizing capacity (HDPE) ④	g/s	119	151	186	219	132	162	193	224	147	177	201	231	187	217	210	241	g/s	Plasticizing capacity (HDPE) ④	
Screw speed	rpm	165				135				116				105				rpm	Screw speed	
OTHERS																		OTHERS		
Max. pump pressure	Mpa	25				25				25				25				Mpa	Max. pump pressure	
Pump motor power	kW	55+30				55+30				75+37				75+55				kW	Pump motor power	
Heating power	kW	54				71				83				104				kW	Heating power	
Machine dimensions (l x w x h)	m	9.29×3.31×2.83				9.39×3.31×2.84				9.85×3.31×2.85				10.52×3.31×4.18				m	Machine dimensions (l x w x h)	
Machine weight	t	43				46				48				52				t	Machine weight	
Hopper capacity	kg	100				100				100				400				kg	Hopper capacity	
Oil tank capacity	l	730				780				960				1250				l	Oil tank capacity	

NOTE:

① with min. mold height / with max. mold height

② moving platen: 2/3 of max. mold weight

③ Plasticizing capacity (GPPS): note: GB standard, with application of GPPS plasticizing capacity of 3-zone screws

④ Plasticizing capacity (HDPE): note: Euromap 19, with application of HDPE plasticizing capacity of barrier screws

The above plasticizing capacity is for reference only.

We reserve the right to make changes as a result of further technical advantages.

DIMENSIONS JU10800III

Clamping Unit

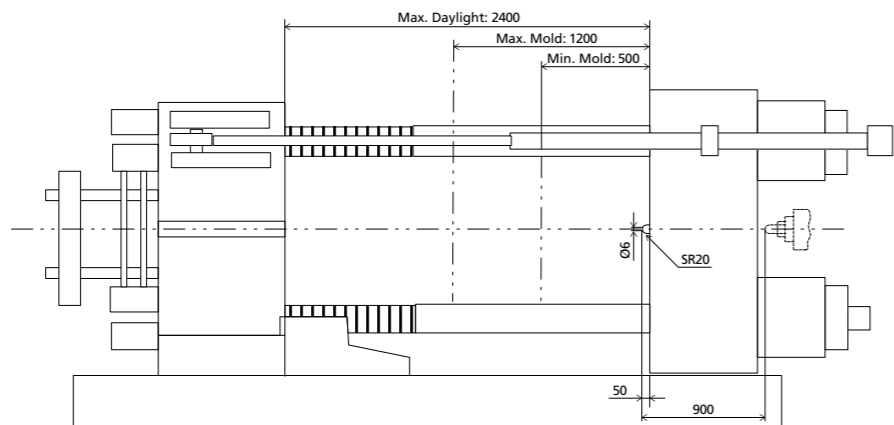

Platen dimensions

Moving platen

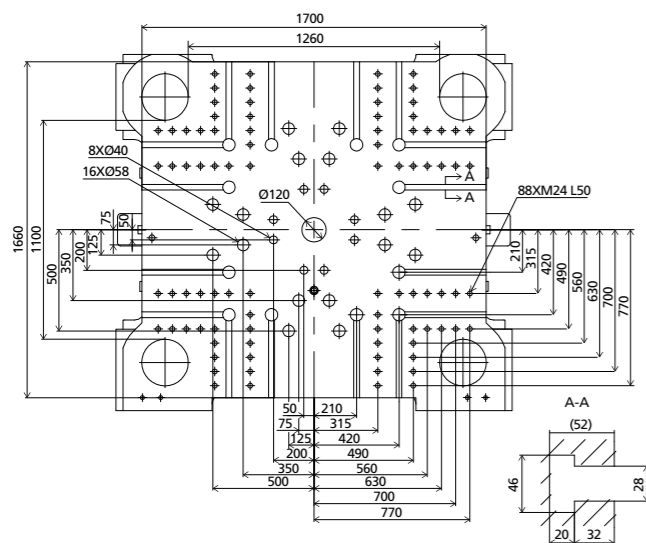

Platen dimensions

Fixed platen

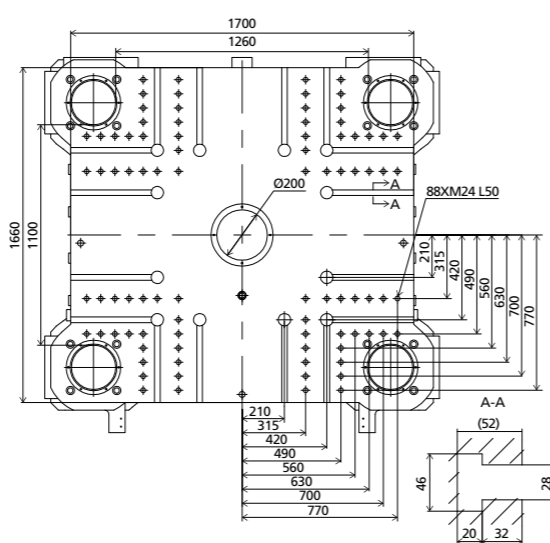

Robot

Mechanical interface

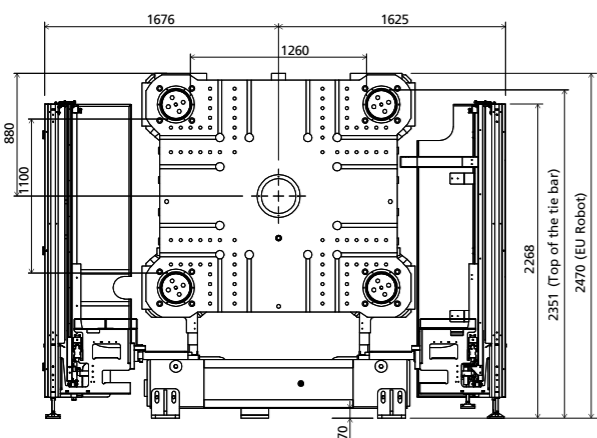

Robot

Top view fixed platen

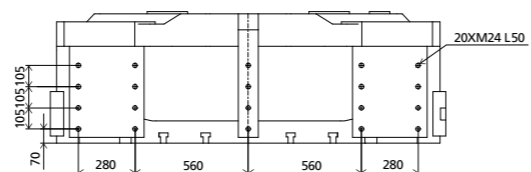

Front view

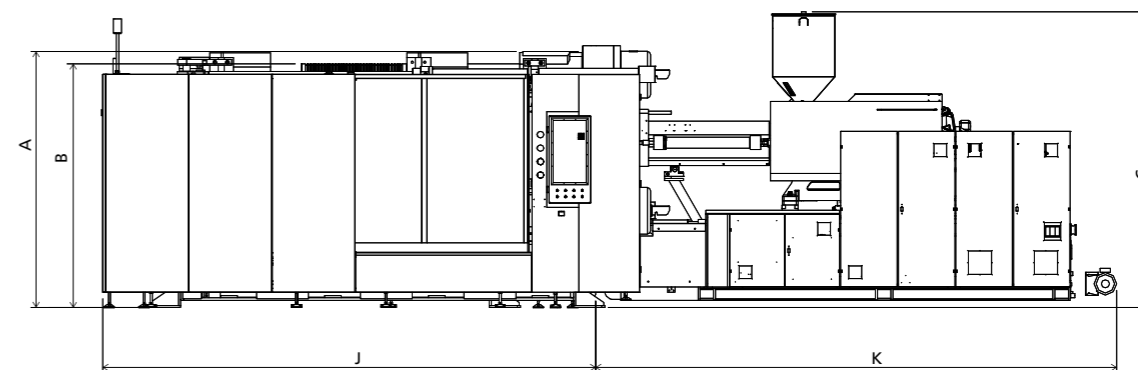

Top view

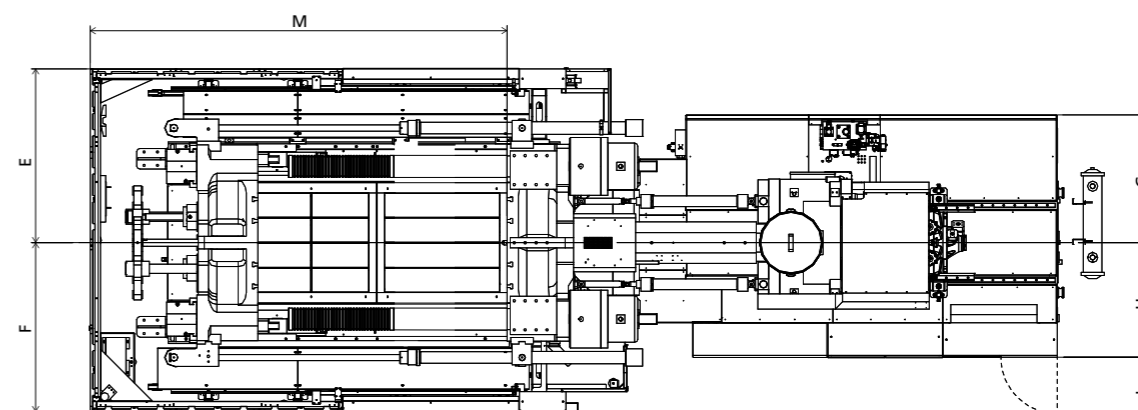

Side view

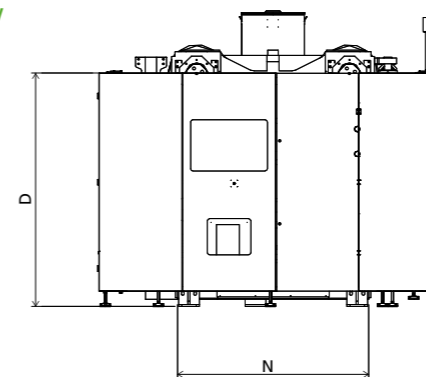

■ Standard

	A	B	C	D	E	F	G	H	I	J	K	M	N
5330	2470	2351	2825	2250	1676	1625	1203	1027	544	4699	4586	4014	1840
6730	2470	2351	2840	2250	1676	1625	1198	1042	544	4699	4689	4014	1840
8930	2470	2351	2850	2250	1676	1625	1228	1102	544	4699	4913	4014	1840
11300	2470	2351	4180	2250	1676	1625	1318	1212	544	4699	5821	4014	1840

INJECTION UNIT
DIMENSIONS (mm)

We reserve the right to make changes as a result of further technical advantages.