

HAITIAN INTERNATIONAL HOLDINGS LIMITED

Unit 1105 Level 11
Metroplaza Tower 2
223 Hing Fong RD Kwai Fong N.T
haitian@mail.haitian.com
www.haitian.com

NINGBO HAITIAN HUAYUAN MACHINERY CO., LTD.

Export Processing Zone, Ningbo 315800 China
+86-574-86177242
+86-574-86221864
haitian@mail.haitian.com
www.haitian.com

HAITIAN HUAYUAN MIDDLE EAST MK. DIS TIC. LTD. STI.

Alkop San.Sit.B/6 Blok No:8-9
Hadımköy/Büyükkçekmece/İstanbul
Tel:0212 858 10 58
Fax:0212 858 10 57
İnternet URL:http// www.haitian.com

Haitian Mars^{2S} Series
Specifications / International
600-12000KN



Haitian Partner:

HT 20180511-TV

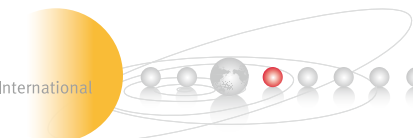

Spesifikasyon

		MA600 II S/130			MA900 II S/280			MA1200 II S/400			MA1600 II S/570			MA2000 II S/750			MA2500 II S/1000			MA2800 II S/1350			
		A	B		A	B	C	A	B	C	A	B	C	A	B	C	A	B	C	A	B	C	
ENJEKSİYON ÜNİTESİ																							
Vida Çapı	mm	24	28		32	36	40	36	40	45	40	45	50	45	50	55	50	55	60	55	60	65	
Vide Boy/Çap oranı	L/D	23.3	20		22.5	20	18	23.3	21	18.7	22.5	20	18	22.2	20	18.2	22	20	18.3	21.8	20	18.5	
Teorik enjeksiyon hacmi	cm ³	50	68		121	153	188	173	214	270	253	320	395	334	412	499	471	570	679	618	735	863	
Enjeksiyon Kapasitesi (PS)	g	45	62		110	139	172	157	194	246	230	291	359	304	375	454	429	519	618	562	669	785	
Enjeksiyon Oranı	g/s	60	82		90	114	141	109	135	171	137	174	215	166	205	248	223	270	322	277	329	386	
Enjeksiyon Basıncı	MPa	250	184		234	185	150	229	186	147	225	178	144	223	180	149	224	185	155	223	188	160	
Plastikleşme Hızı (PS)	g/s	6.0	8.6		12.5	16.5	20.0	17.8	21.8	28.8	21.2	28.1	35.3	23.9	30.0	36.7	38.1	46.7	55.3	45.9	54.5	60.6	
Vida Devir Hızı	rpm	0-310			0-285			0-275			0-255			0-200			0-235			0-255			
MENGENE ÜNİTESİ																							
Kilitleme Gücü	kN	600			900			1200			1600			2000			2500			2800			
Mengene Stroğu	mm	270			310			360			430			490			540			590			
Kolonlar Arası Mesafe	mm	310x310			360x360			410x410			470x470			530x530			580x580			630x630			
Max.Kalıp Kalınlığı	mm	330			390			450			520			550			580			630			
Min.Kalıp Kalınlığı	mm	120			150			150			180			200			220			230			
İtici Stroğu	mm	70			100			120			140			140			150			150			
İtici Gücü	kN	22			33			33			33			62			62			62			
DIĞERLERİ																							
Pompa motor Gücü	kW	11			13			15			18.5			22			30			37			
Isıtıcı Gücü	kW	6.3			7.7			11.75			11.75			16.95			17.8			23.4			
Makina Boyutları	m	3.8X1.1X1.9			4.2X1.2X1.9			4.6X1.3X2.0			5.2X1.4X2.0			5.6X1.4X2.2			6.1X1.5X2.3			6.8X1.7X2.3			
Makina Ağırlığı	t	2.5			3.5			4.35			5.65			7.1			8.4			11			
Mal Hazne Kapasitesi	kg	25			25			25			25			50			50			50			
Yağ Tankı Kapasitesi	l	120			150			170			210			250			340			440			

Plaka Ebatları

Hareketli Plaka

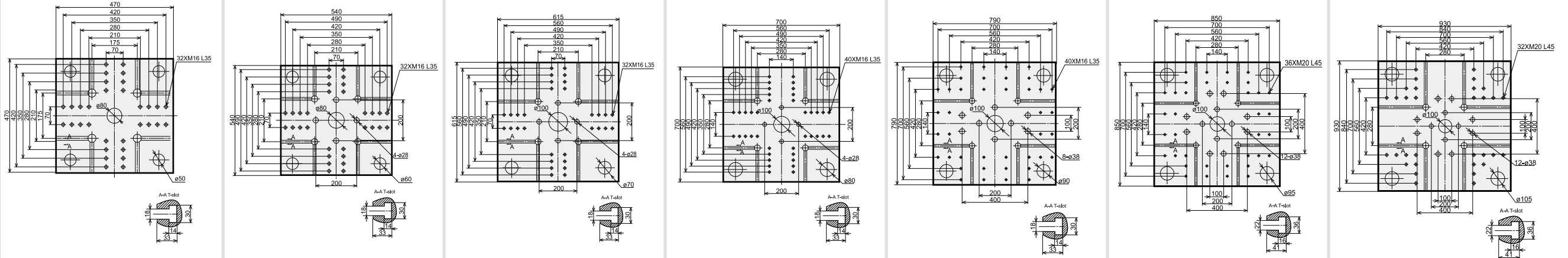

Plaka Ebatları

Robot bağlantı delikleri sabit plakada

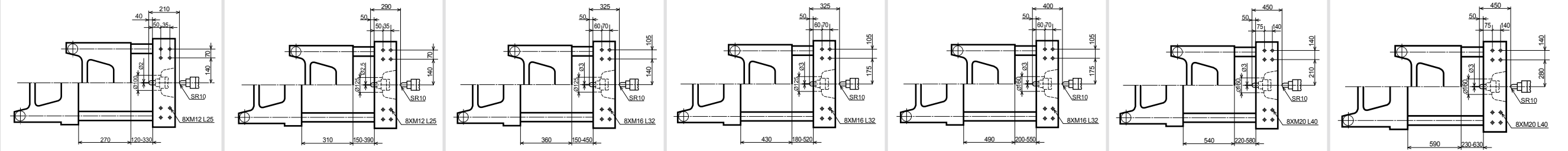

Makina Boyutları

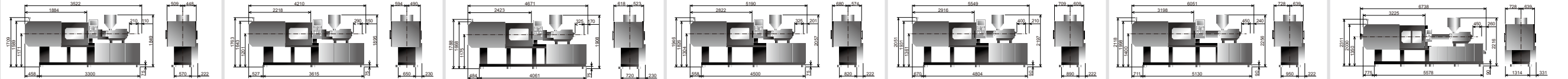

We reserve the right to make changes as a result of further technical advantages.

Spesifikasyon

ENJEKSİYON ÜNİTESİ

		MA3200 II S/1700			MA3800 II S/2250				MA4700 II S/3200				MA5300 II S/4500				MA6000 II S/4500			
		A	B	C	A	B	C	D	A	B	C	D	A	B	C	D	A	B	C	D
Vida Çapı	mm	60	65	70	65	70	75	80	70	80	85	90	80	85	90	100	80	85	90	100
Vide Boy/Çap oranı	L/D	21.7	20	18.6	21.5	20	18.7	17.5	22.9	20	19.1	17.8	22.2	20.7	19.6	17.6	22.2	20.7	19.6	17.6
Teorik enjeksiyon hacmi	cm ³	792	929	1078	1068	1239	1423	1619	1424	1860	2100	2354	2212	2497	2799	3456	2212	2497	2799	3456
Enjeksiyon Kapasitesi (PS)	g	720	846	981	972	1128	1295	1473	1296	1692	1911	2142	2013	2272	2547	3145	2013	2272	2547	3145
Enjeksiyon Oranı	g/s	289	339	394	351	407	467	531	395	516	583	653	551	622	698	861	551	622	698	861
Enjeksiyon Basıncı	MPa	213	182	157	212	183	159	140	224	172	152	136	197	175	156	126	197	175	156	126
Plastikleşme Hızı (PS)	g/s	51.1	56.7	64.4	58.7	67.3	76	84	67.9	89.5	98.2	111.0	80.3	88.8	101.0	123.4	80.3	88.8	101.0	123.4
Vida Devir Hızı	rpm	0-225			0-220				0-210				0-180				0-180			

MENGENE ÜNİTESİ

Kilitleme Gücü	kN	3200			3800				4700				5300				6000			
Mengene Stroğu	mm	640			700				780				850				900			
Kolonlar Arası Mesafe	mm	680x680			730x730				820x800				840x830				880x880			
Max.Kalıp Kalınlığı	mm	680			730				780				850				880			
Min.Kalıp Kalınlığı	mm	250			280				320				350				380			
İtici Stroğu	mm	160			180				200				220				240			
İtici Gücü	kN	62			110				110				158				158			

DIĞERLERİ

Pompa motor Gücü	kW	37			45				55				65				65			
Isıtıcı Gücü	kW	27			33				38.95				47.95				47.95			
Makina Boyutları	m	7.2x1.7x2.3			7.5x1.8x2.5				8.2x1.9x3.0				8.9x2.1x3.4				9.2x2.1x3.4			
Makina Ağırlığı	t	13.2			14.7				18.5				26				29			
Mal Hazne Kapasitesi	kg	50			50				50				100				100			
Yağ Tankı Kapasitesi	l	500			540				640				800				800			

Plaka Ebatları

Hareketli Plaka

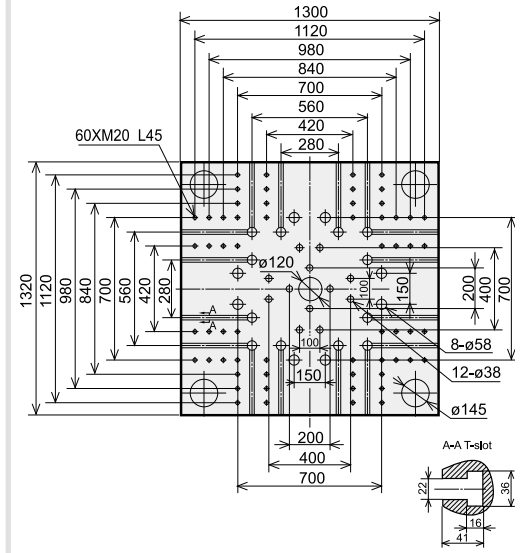
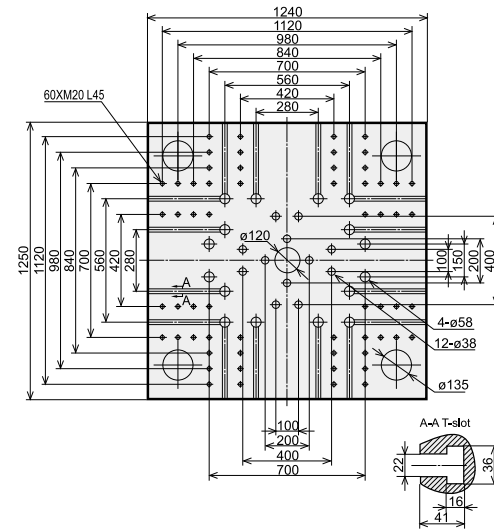
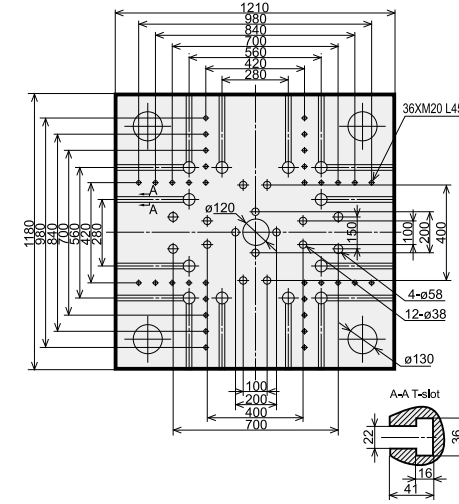
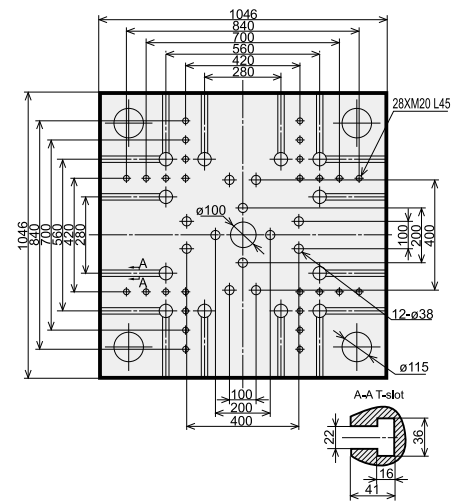
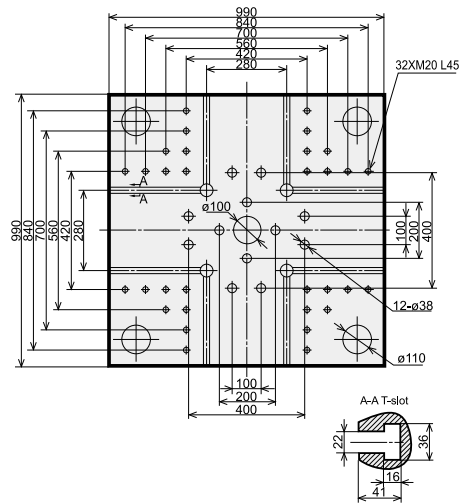

Plaka Ebatları

Robot bağlantı delikleri sabit plakada

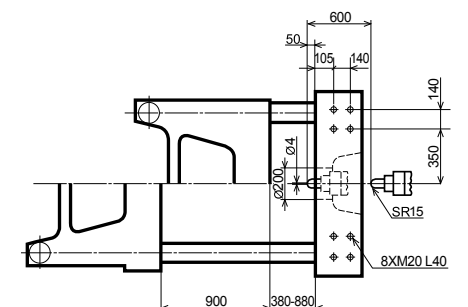
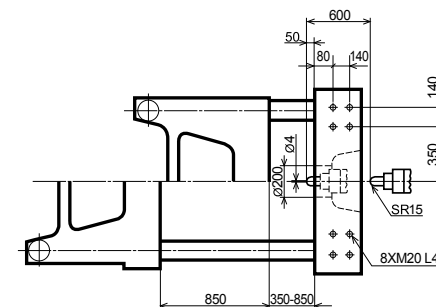
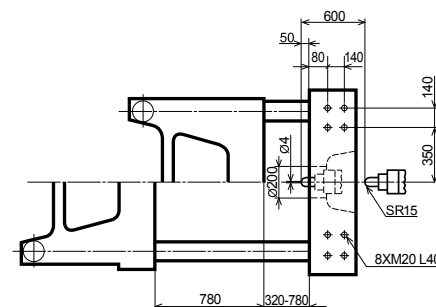
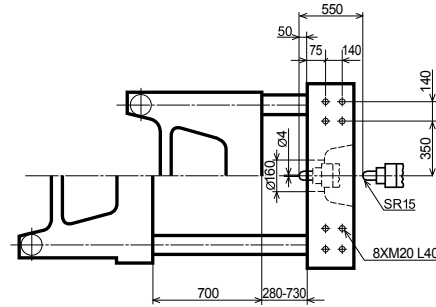
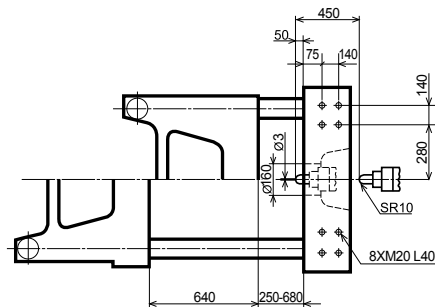

Makina Boyutları

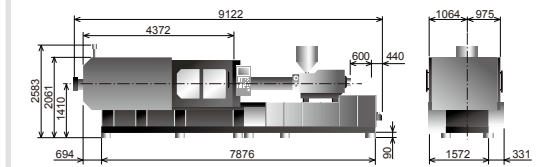
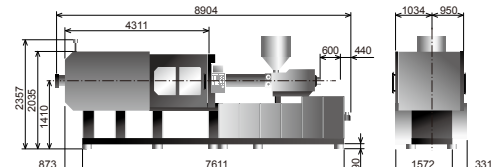
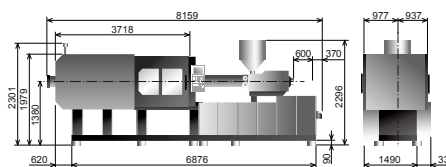
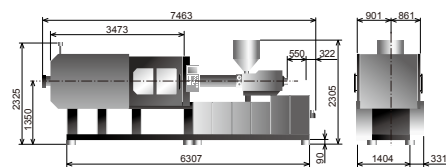
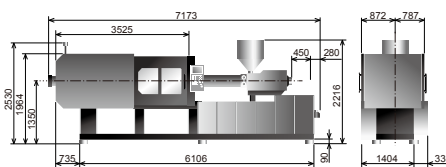

We reserve the right to make changes as a result of further technical advantages.

Spesifikasyon

ENJEKSİYON ÜNİTESİ

Vida Çapı	mm	80	90	100	110
Vide Boy/Çap oranı	L/D	24.8	22	19.8	18
Teorik enjeksiyon hacmi	cm ³	2262	2863	3534	4276
Enjeksiyon Kapasitesi (PS)	g	2058	2605	3216	3892
Enjeksiyon Oranı	g/s	492	623	769	930
Enjeksiyon Basıncı	MPa	226	179	145	120
Plastikleşme Hızı (PS)	g/s	73.8	92.6	114	134
Vida Devir Hızı	rpm	0-151			

MENGENE ÜNİTESİ

Kilitleme Gücü	kN	7000			
Mengene Stroğu	mm	970			
Kolonlar Arası Mesafe	mm	960x940			
Max.Kalıp Kalınlığı	mm	940			
Min.Kalıp Kalınlığı	mm	400			
İtici Stroğu	mm	260			
İtici Gücü	kN	186			

DIĞERLERİ

Pompa motor Gücü	kW	22+45			
Isıtıcı Gücü	kW	54.25			
Makina Boyutları	m	10.3X2.3X3.5			
Makina Ağırlığı	t	32			
Mal Hazne Kapasitesi	kg	100			
Yağ Tankı Kapasitesi	l	880			

MA7000 II S/5000

A	B	C	D
80	90	100	110
24.8	22	19.8	18
2262	2863	3534	4276
2058	2605	3216	3892
492	623	769	930
226	179	145	120
73.8	92.6	114	134

MA8000 II S/6800

A	B	C	D
90	100	110	120
24.4	22	20	18.3
2990	3691	4467	5316
2721	3359	4065	4837
573	707	855	1018
219	178	147	123
88.8	109	129	151

MA9000 II S/6800

A	B	C	D
90	100	110	120
24.4	22	20	18.3
2990	3691	4467	5316
2721	3359	4065	4837
573	707	855	1018
219	178	147	123
88.8	109	129	151

MA10000 II S/8400

A	B	C	D
100	110	120	130
24.2	22	20.2	18.6
4006	4847	5768	6769
3645	4410	5249	6160
705	853	1015	1191
213	176	148	126
100	120	139	160

MA12000 II S/8400

A	B	C	D
100	110	120	130
24.2	22	20.2	18.6
4006	4847	5768	6769
3645	4410	5249	6160
705	853	1015	1191
213	176	148	126
100	120	139	160

Plaka Ebatları

Hareketli Plaka

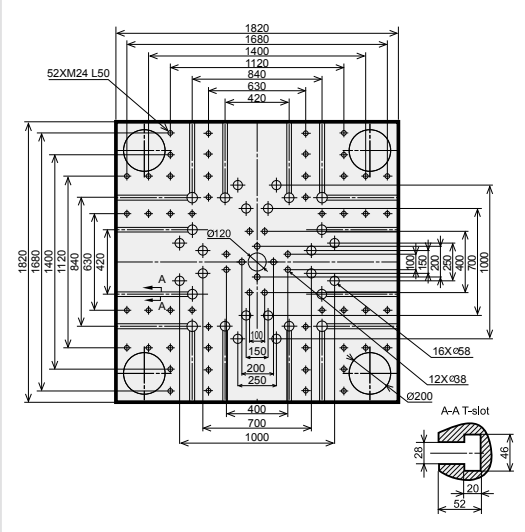
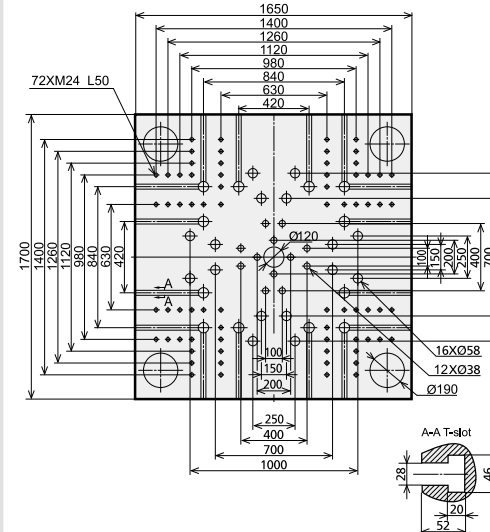
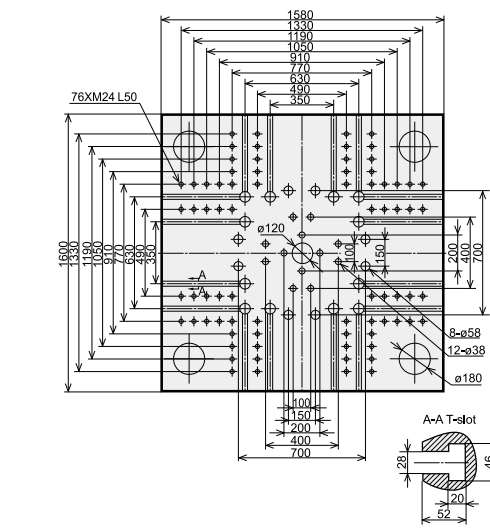
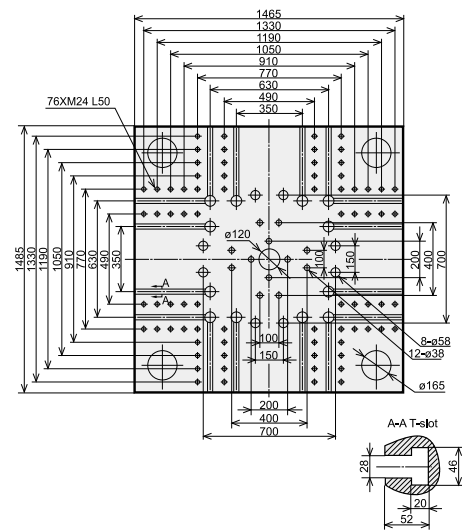
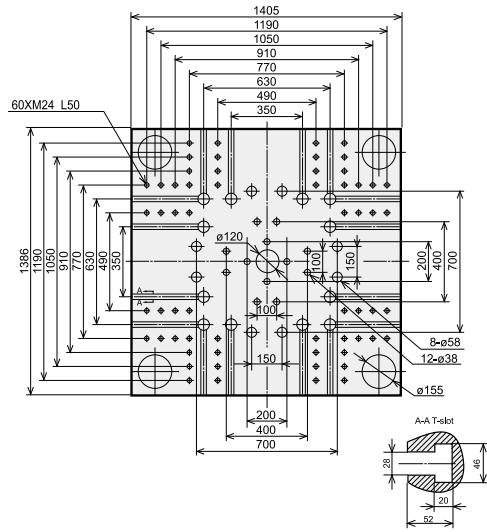

Plaka Ebatları

Robot bağlantı delikleri sabit plakada

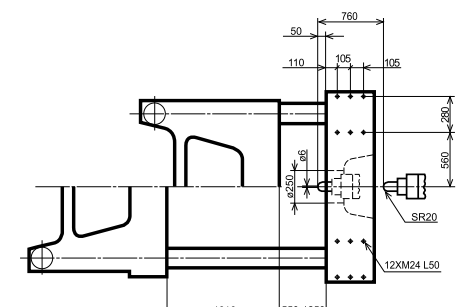
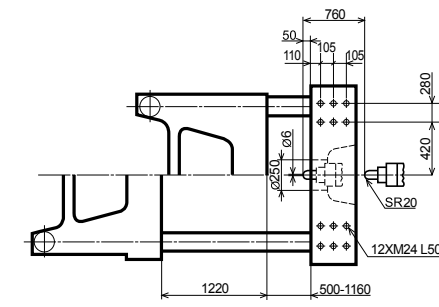
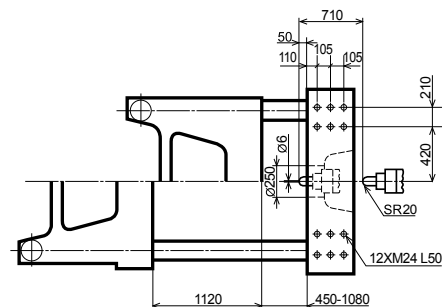
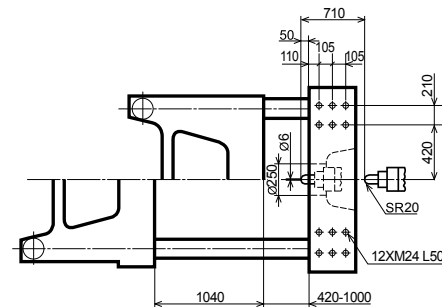
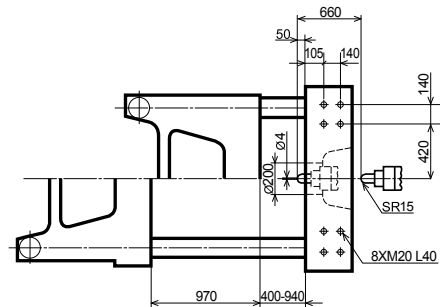

Makina Boyutları

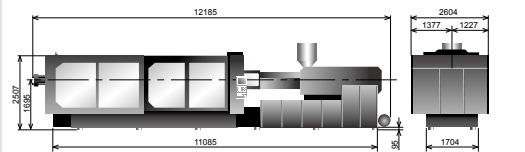
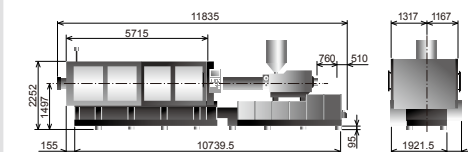
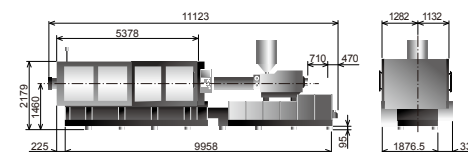
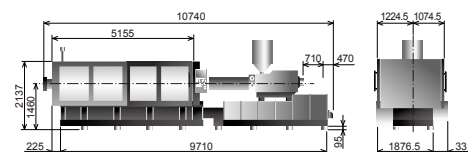
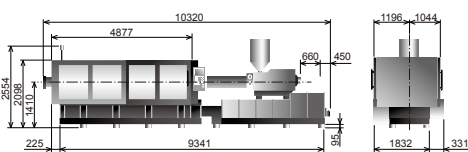

We reserve the right to make changes as a result of further technical advantages.